

n ≈ 1450 rpm

پمپ WKLV4, WKL 4 80

تیپ پمپ	توان P		آمپر A	قطر پروانه D (mm)	قطر فلنج mm		Q آبدهی								
	KW	HP			مکش	رانس	m ³ /h	20	40	50	60	70	80	90	100
							l/s	5.6	11.1	13.9	16.7	19.5	22.2	25	27.8
WKLV4 80.1 C	2.2	3	5	180	100	80	H (m)	11	9.5	8.4	7	4.8	*	*	*
WKLV4 80.1 B	4	5.5	9	205				15	13.4	12.2	10.7	9.1	7.2	5	*
WKLV4 80.1 A	5.5	7.5	12	220				18	16.5	15.5	14.2	12.8	11	9.2	6.9
WKLV4 80.2 C	5.5	7.5	12	180				22	19	16.8	13.8	9.5	*	*	*
WKLV4 80.2 B	7.5	10	16	205				30	26.7	24.5	21.6	18.2	14.3	10	*
WKLV4 80.2 A	11	15	22	220				36	33	31	28.5	25.6	22.4	18.5	14
WKLV4 80.3 C	7.5	10	16	180				33	28.5	25.2	20.7	14.25	*	*	*
WKLV4 80.3 B	11	15	22	205				45	40	36.7	32.4	27.5	21.5	15	*
WKLV4 80.3 A	15	20	30	220				54	49.5	46.3	42.7	38.4	33.6	28	21
WKLV4 80.4 C	11	15	22	180				44	38	33.6	27.7	19	*	*	*
WKLV4 80.4 B	15	20	30	205				60	53.4	49	43.2	36.6	28.6	20	*
WKLV4 80.4 A	18.5	25	38	220				72	66	61.8	57	51.2	44.8	37.4	28
WKLV4 80.5 C	11	15	22	180				55	47.4	41.8	34.6	23.7	*	*	*
WKLV4 80.5 B	18.5	25	38	205				75	66.7	61.2	54	45.7	35.7	25	*
WKLV4 80.5 A	22	30	43.5	220				90	82.4	77.2	71.2	64	56.2	47.5	36.2
WKLV4 80.6 C	15	20	30	180				66	57	50.4	41.7	28.5	*	*	*
WKLV4 80.6 B	22	30	43.5	205				90	80	73.5	64.8	55	43	30	*
WKLV4 80.6 A	30	40	58	220				108	99	92.6	85.5	77	67.5	57	43.5
WKLV4 80.7 C	15	20	30	180				77	66.8	58.8	48.6	33.2	*	*	*
WKLV4 80.7 B	22	30	43.5	205				105	93.4	85.7	75.6	64	51	36	*
WKLV4 80.7 A	37	50	71	220	126	115.5	108.2	99.7	89.6	78.8	66	50			
WKLV4 80.8 C	18.5	25	38	180	88	76	67.2	55.6	38	*	*	*			
WKLV4 80.8 B	30	40	58	205	120	106.8	98	86.4	73.2	58	41	*			
WKLV4 80.8 A	37	50	71	220	144	132	123.6	114	102.4	89.8	75	57			

H	m	4.6	9	18	27	40	52	67	82	98	113	128	146
	ft	15	30	60	90	130	170	220	270	320	370	420	480

Q	m ³ /h	20	40	50	60	70	80	90	100
	g.p.m	76	150	190	227	265	303	340	378

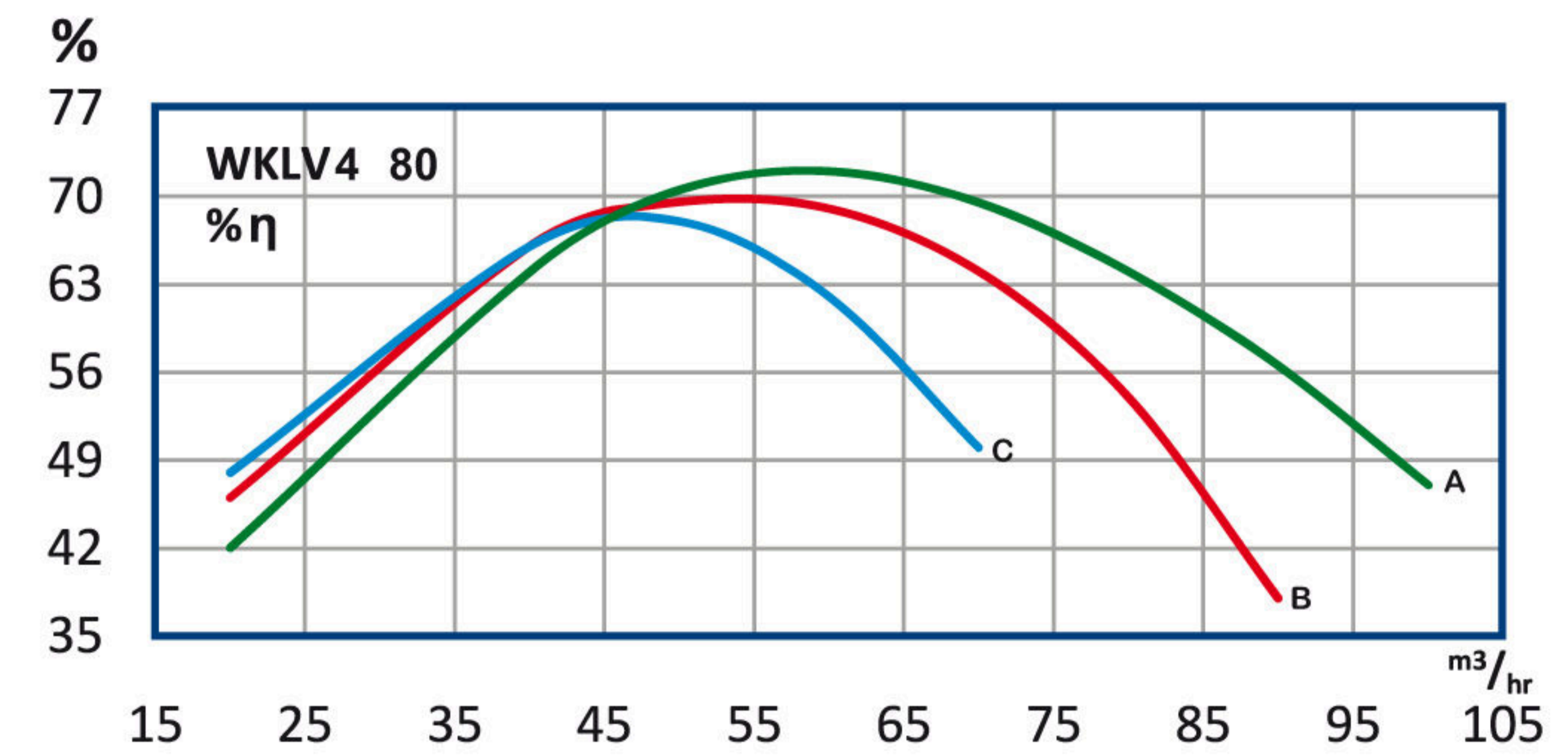
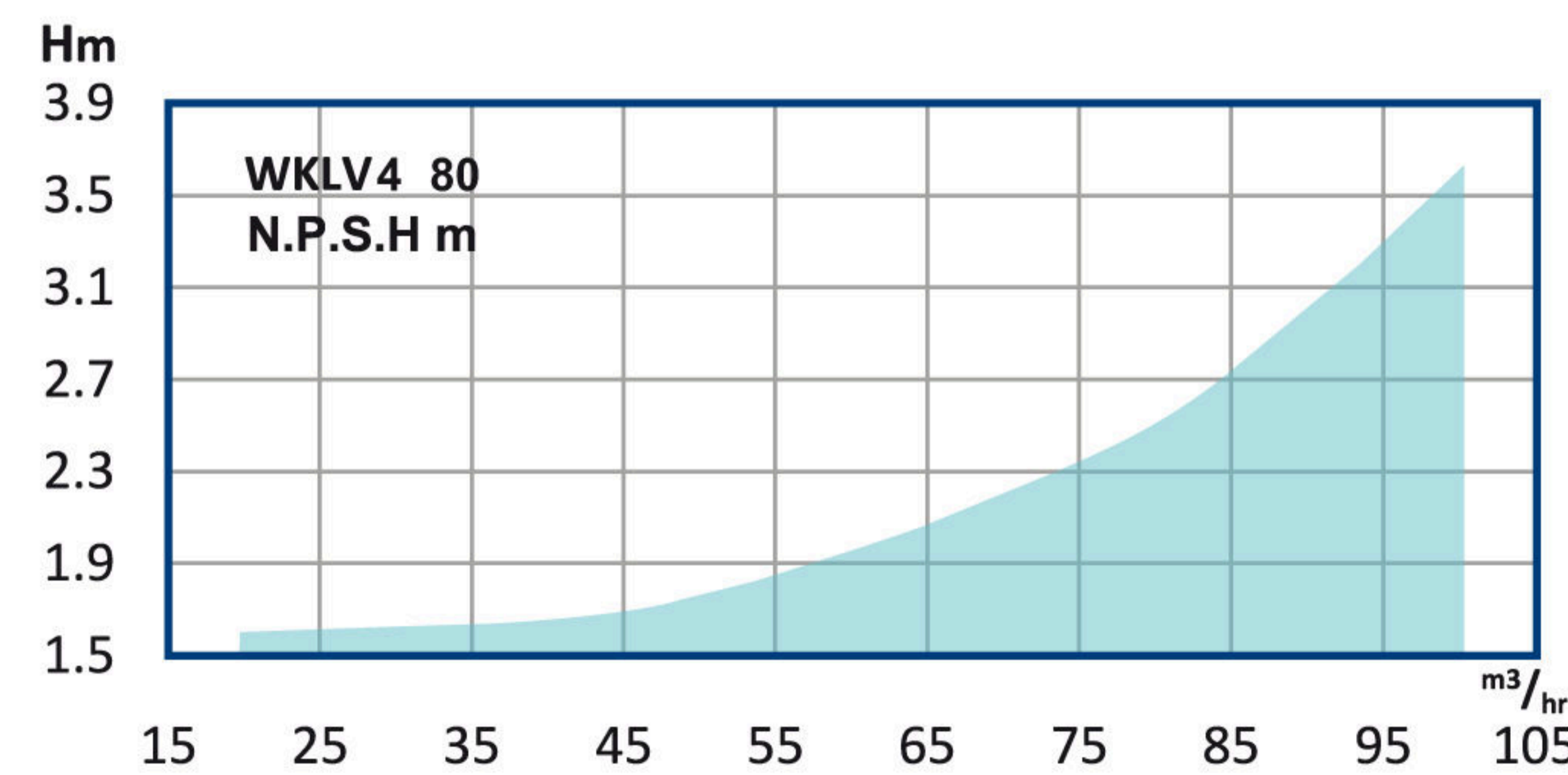
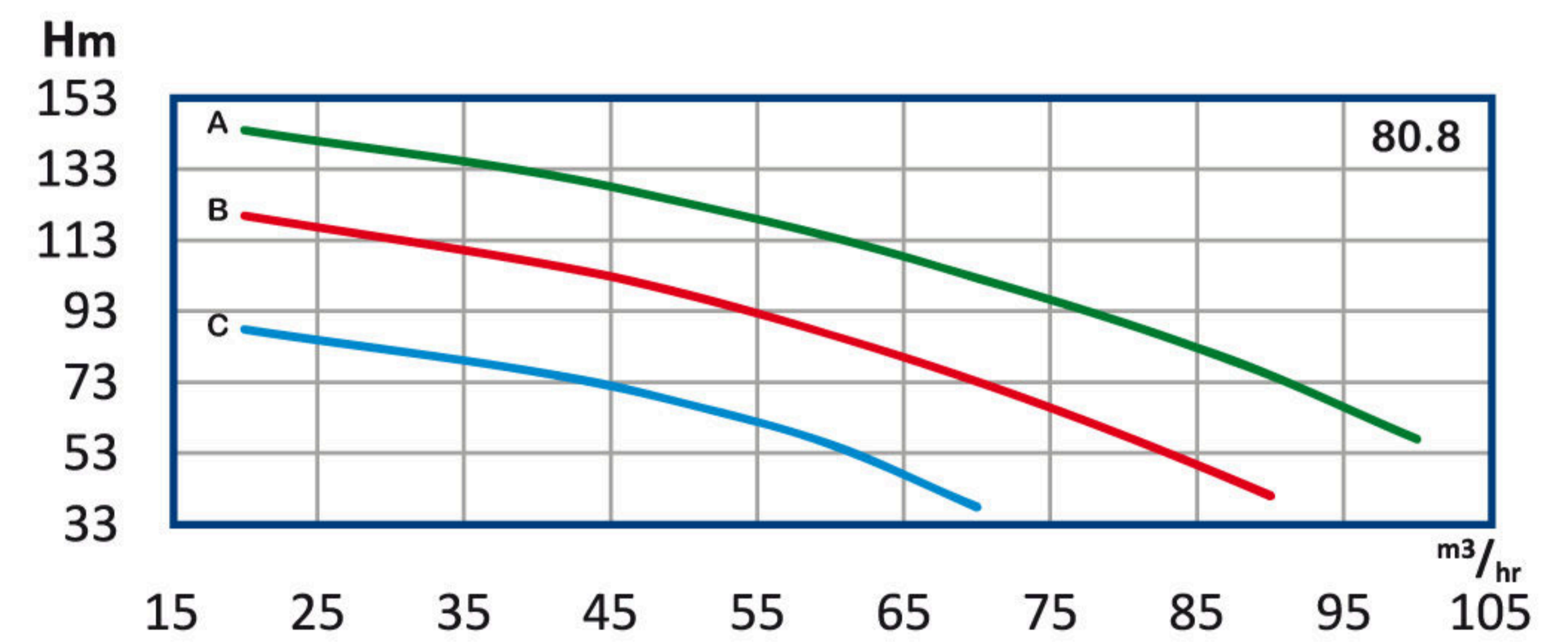
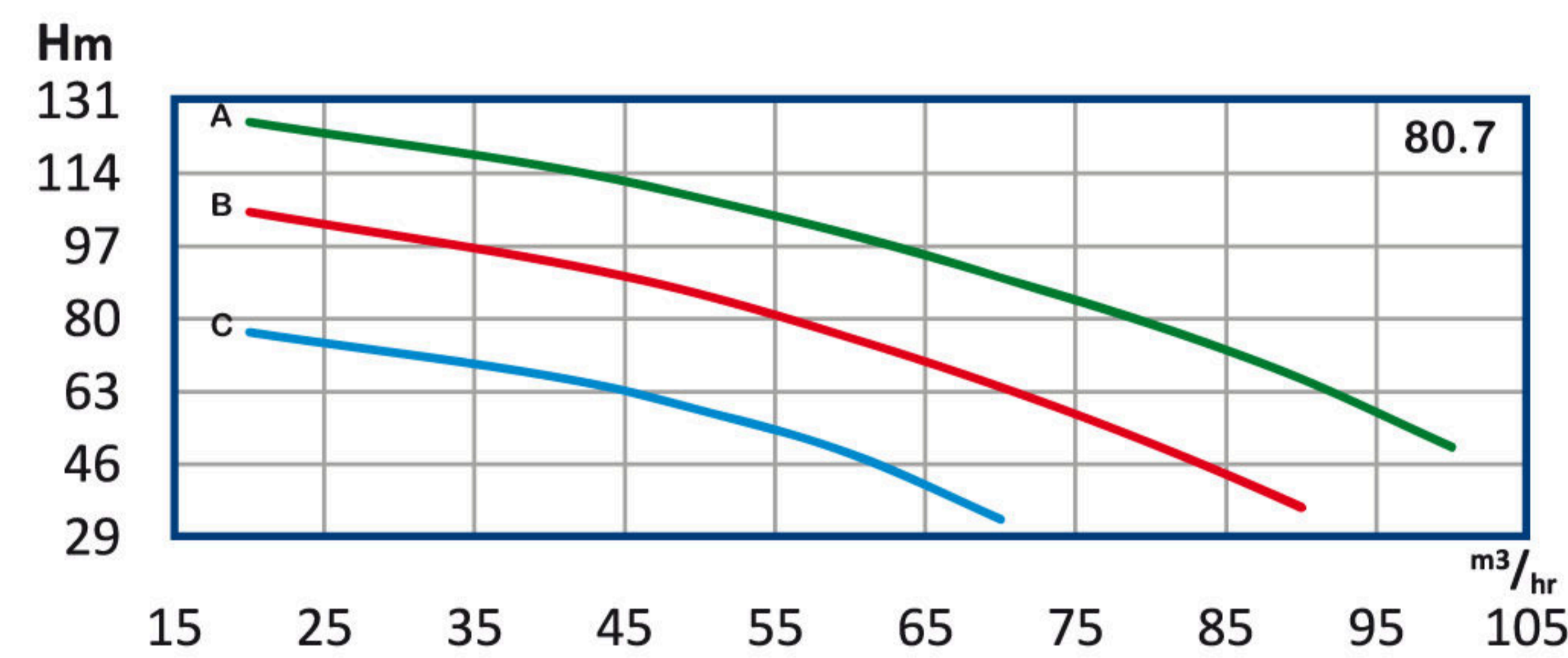
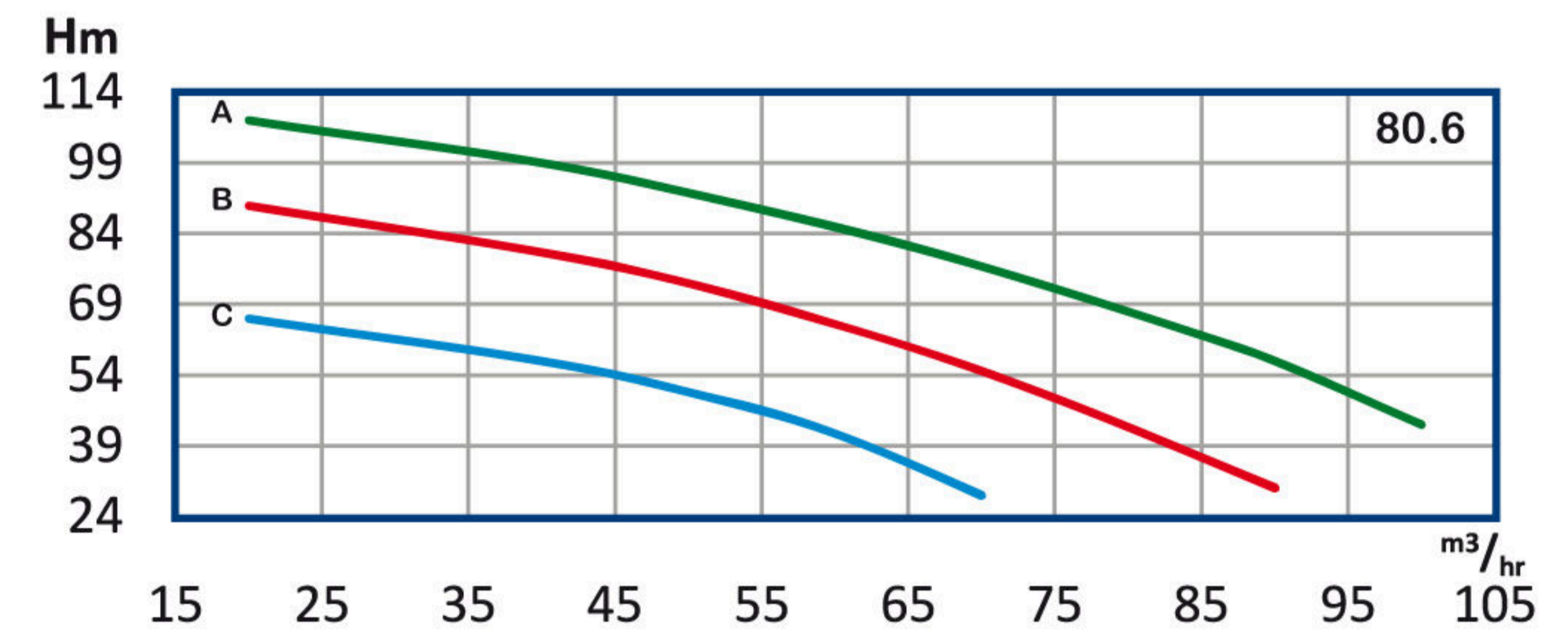
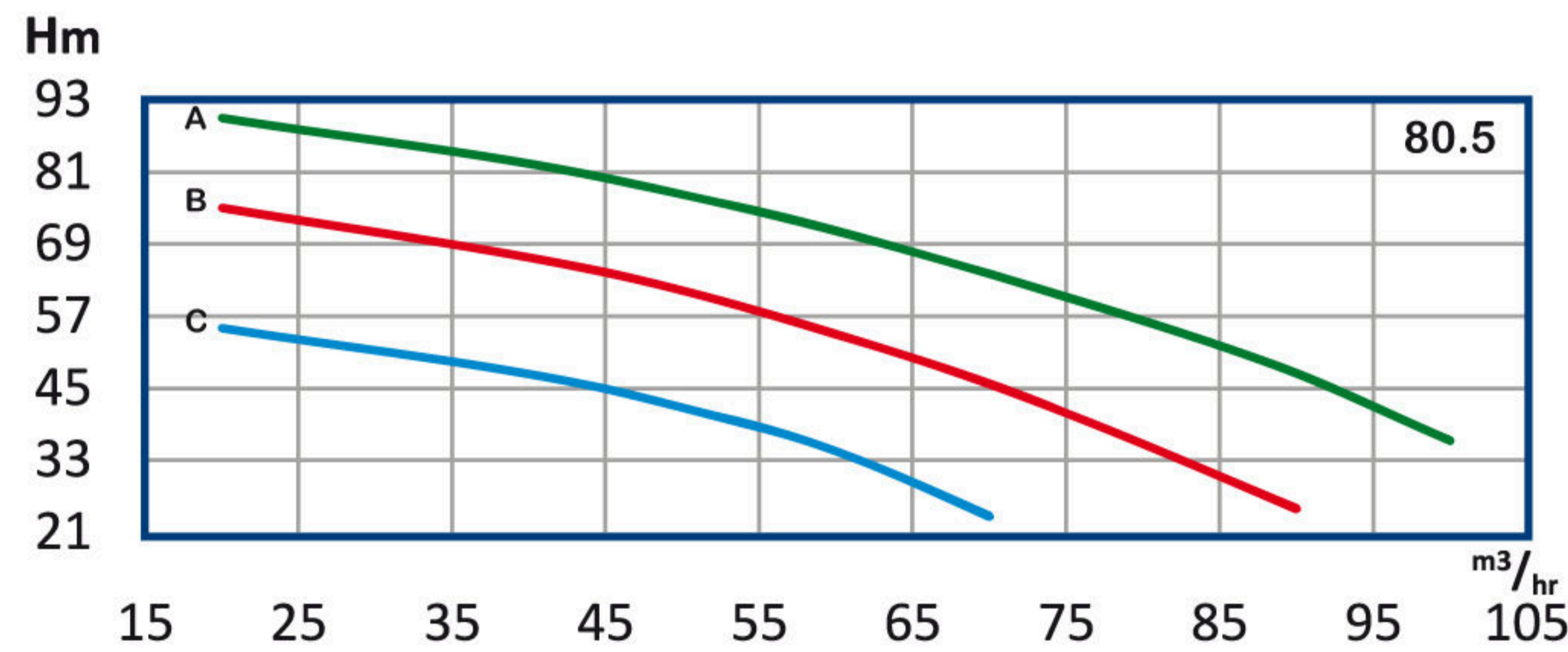
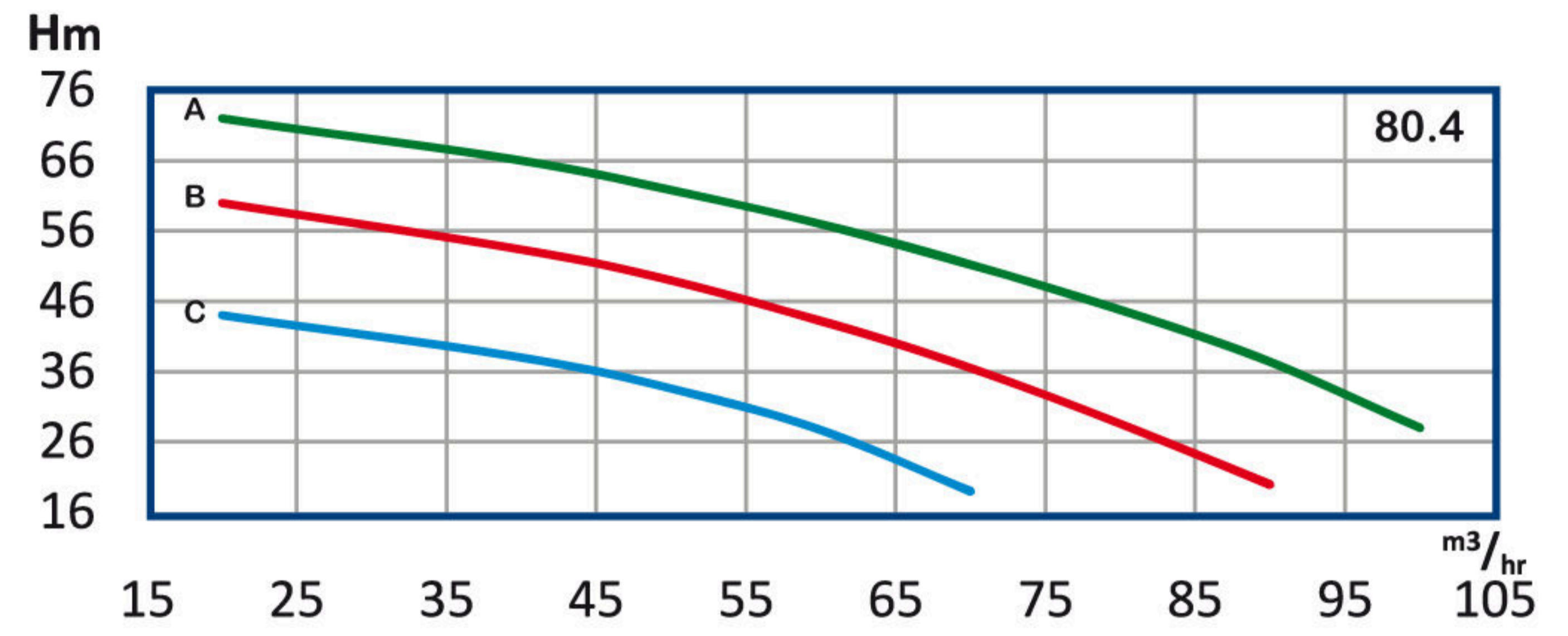
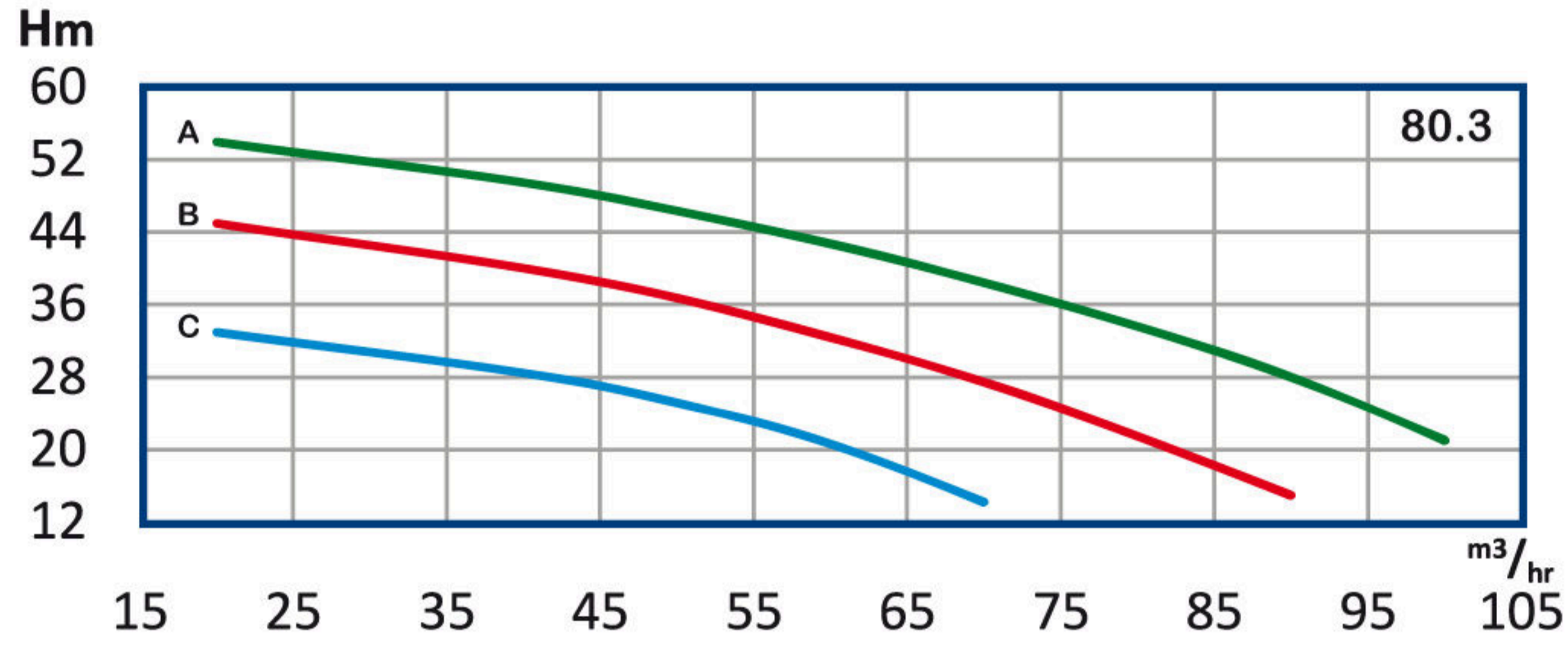
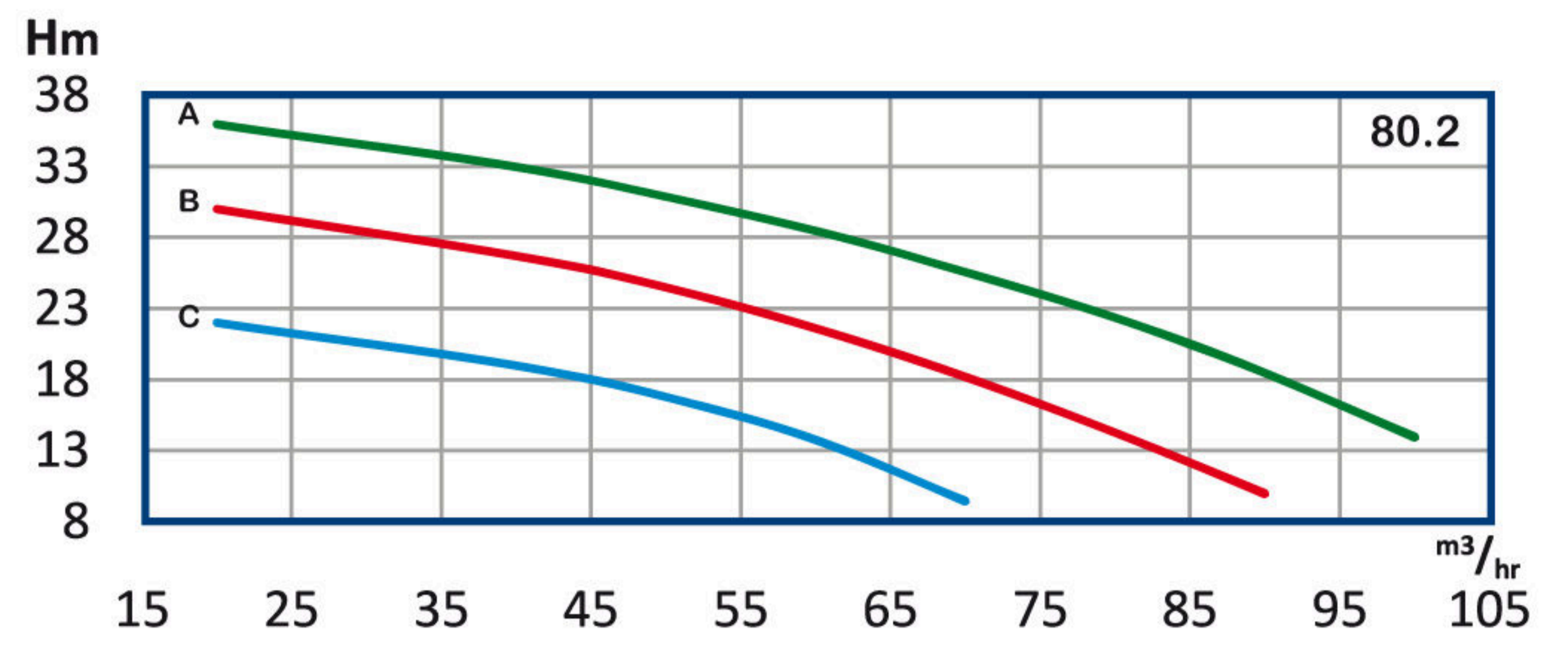
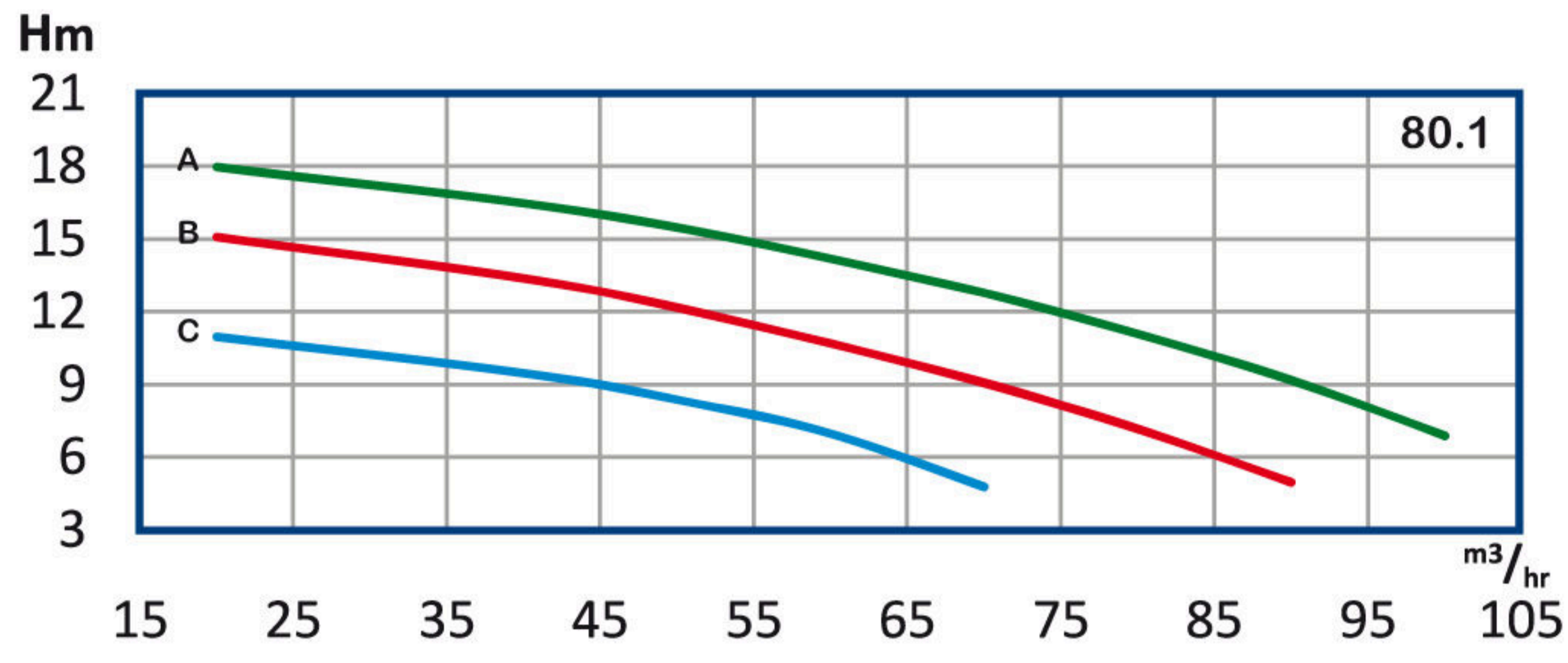

n≈ 1450 rpm

پمپ 80 WKLV4, WKL 4

تیپ پمپ	توان P		آمپر A	قطر پروانه D (mm)	قطر فلنج mm		Q آبدھی								
	KW	HP			مکش	رانس	m3/h	20	40	50	60	70	80	90	100
								l/s	5.6	11.1	13.9	16.7	19.5	22.2	25
WKLV4 80.9 C	22	30	43.5	180	100	80	H (m)	99	85.5	75.6	62.5	42.7	*	*	*
WKLV4 80.9 B	30	40	58	205				135	120.2	110.3	97.2	82.5	65	46	*
WKLV4 80.9 A	45	60	87	220				162	148.5	139	129	116	101.3	85.5	65.2
WKLV4 80.10 C	22	30	43.5	180				110	95	84	69.5	47.5	*	*	*
WKLV4 80.10 B	37	50	71	205				150	133.5	122.5	108	91.6	72	51	*
WKLV4 80.10 A	45	60	87	220				180	165	154.5	142.5	128	112	93	71
WKLV4 80.11 C	30	40	58	180				121	104.5	92.4	76.4	52.2	*	*	*
WKLV4 80.11 B	37	50	71	205				165	147	134.8	118.8	101	80	56	*
WKLV4 80.11 A	55	75	104	220				198	181.5	170	156.8	140.8	123	102	77
WKLV4 80.12 C	30	40	58	180				132	114	100.8	83.4	57	*	*	*
WKLV4 80.12 B	45	60	87	205				180	160.2	147	129.6	109.8	85.8	60	*
WKLV4 80.12 A	55	75	104	220				216	198	185.4	171	153.6	135	112	85

H	m	41	53	66	78	93	108	126	145	163	181	201	220
	ft	135	175	215	255	305	355	415	475	535	595	660	720

Q	m3 /h	20	40	50	60	70	80	90	100
	g.p.m	76	150	190	227	265	303	340	378

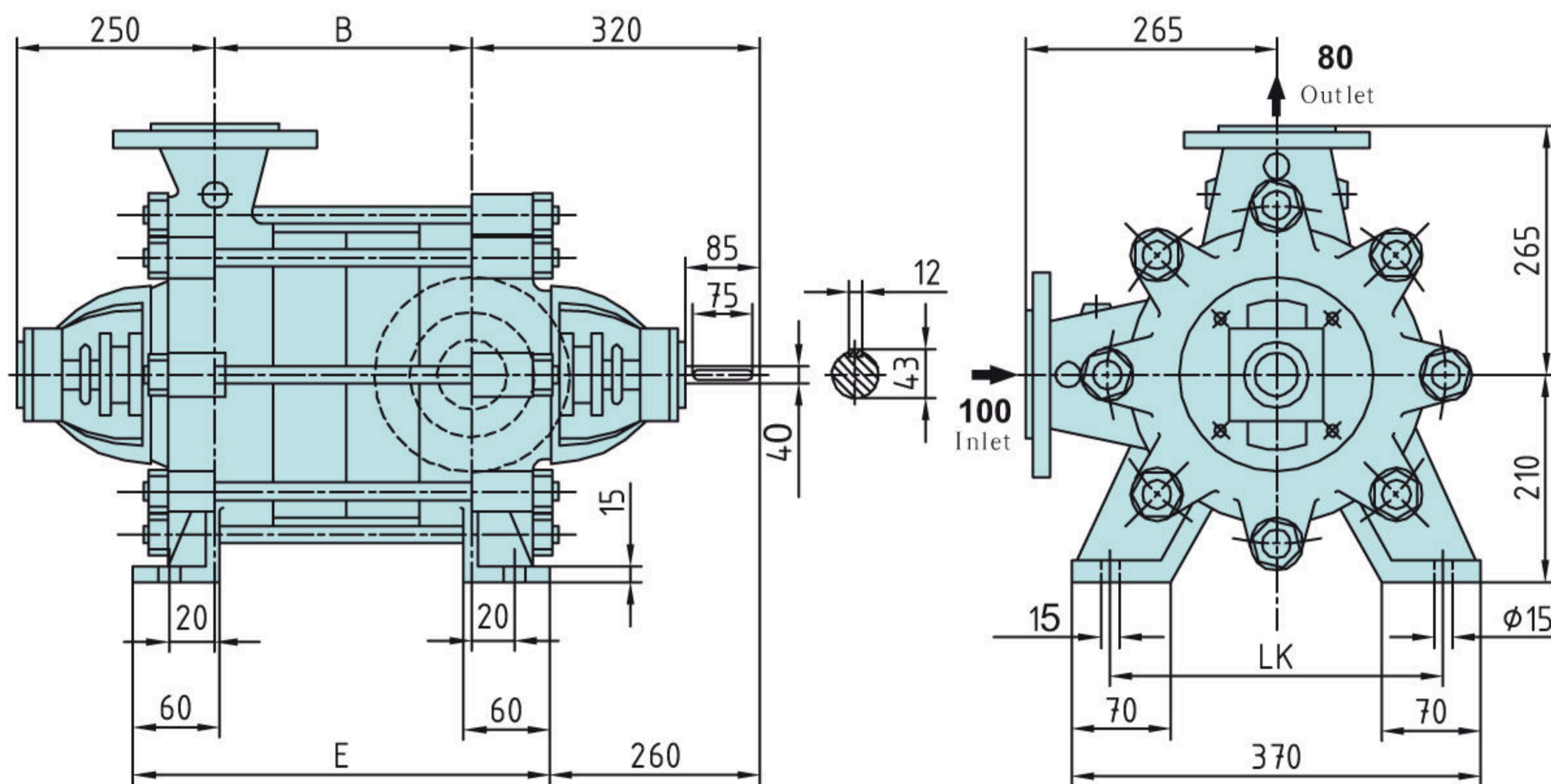
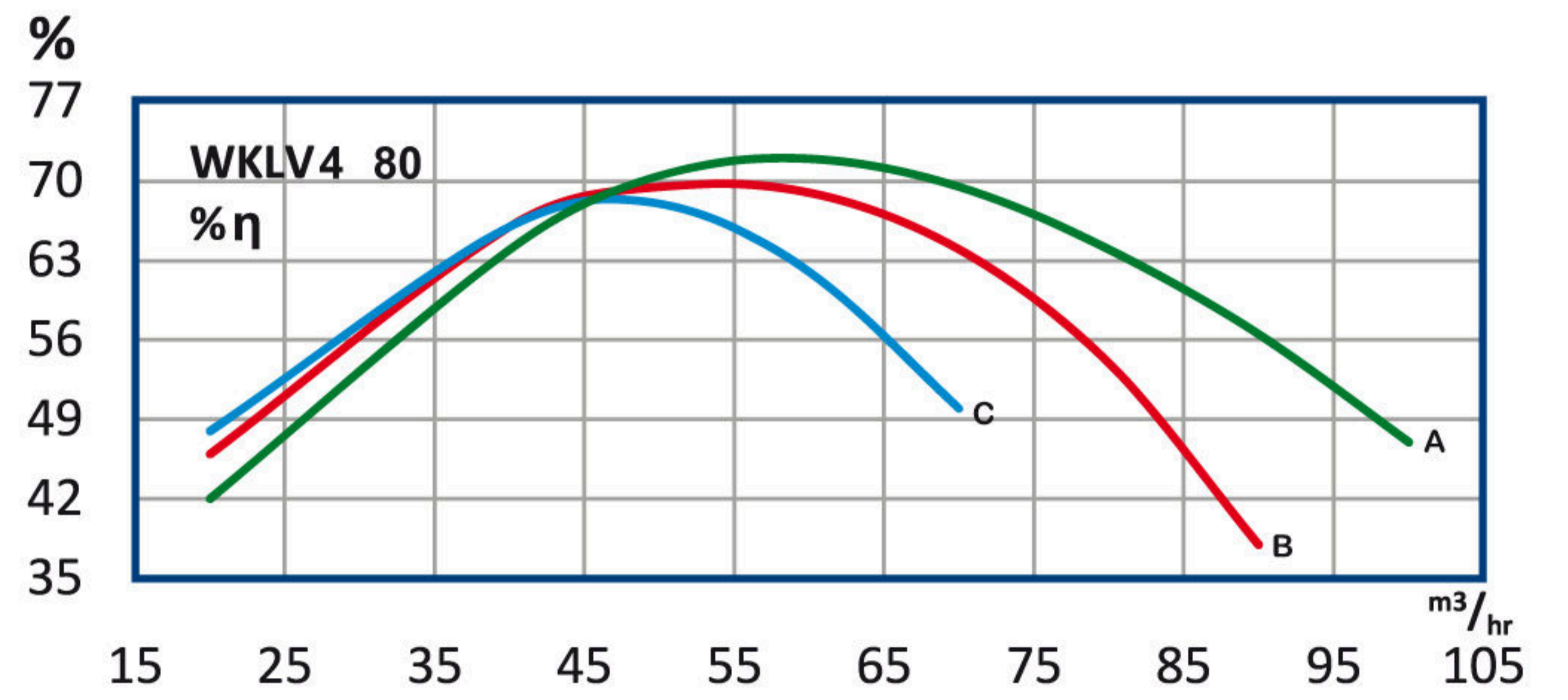
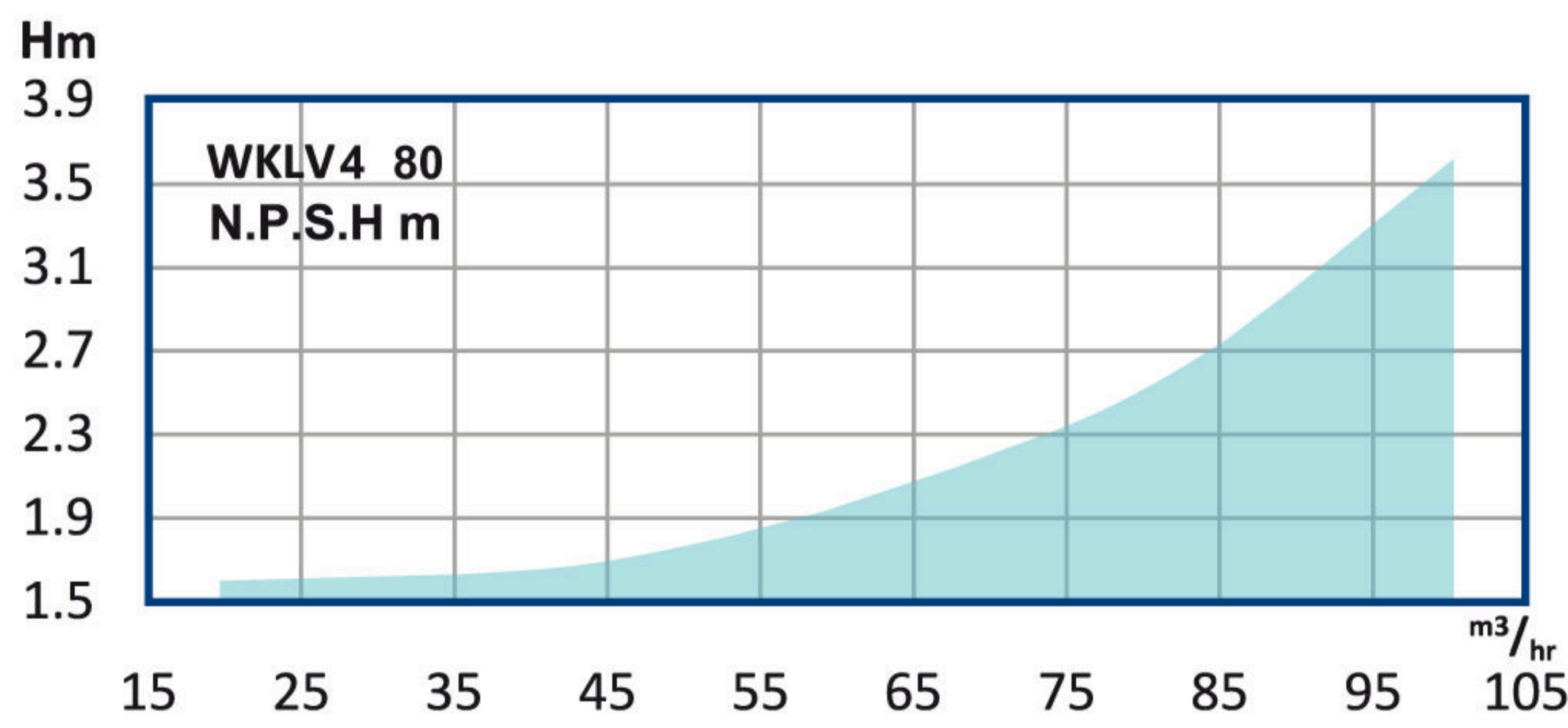
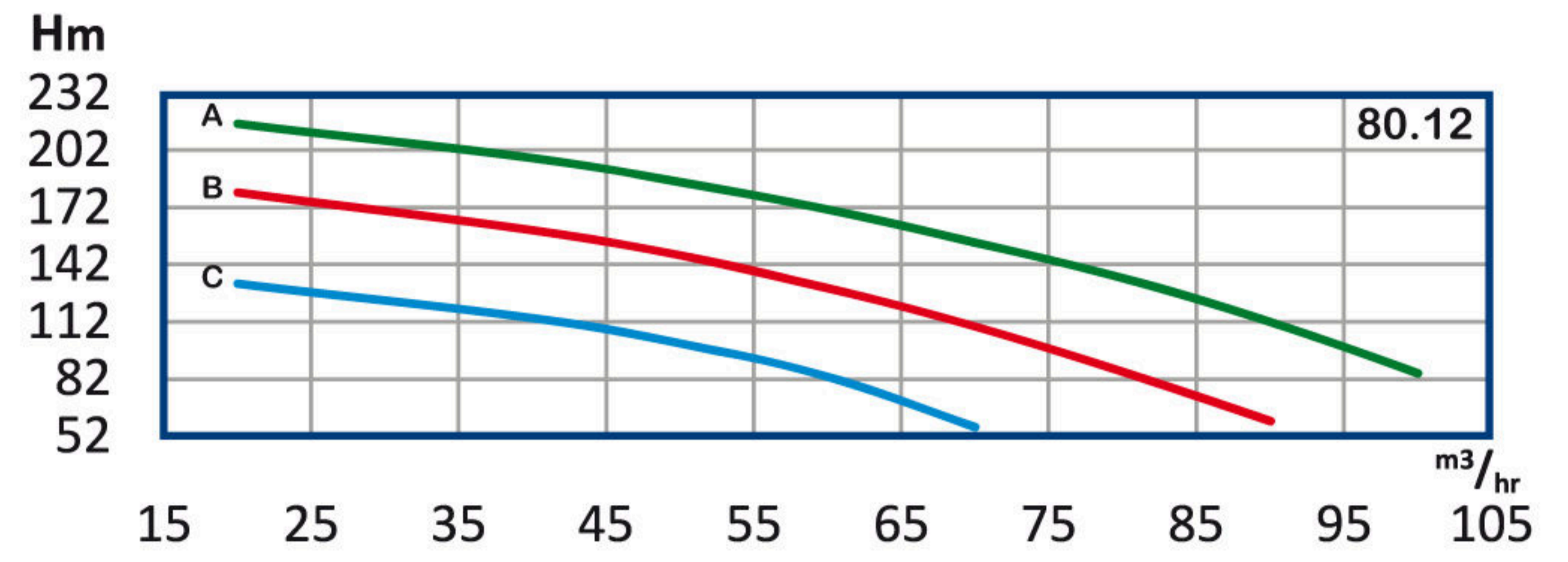
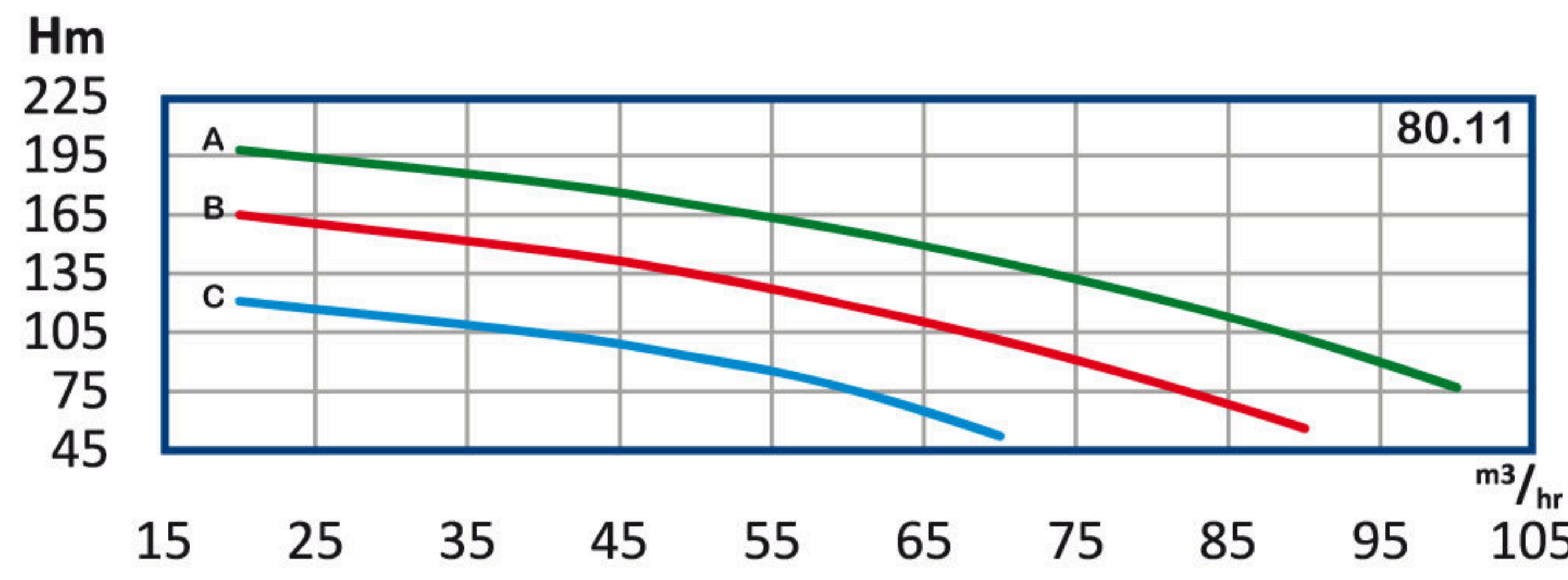
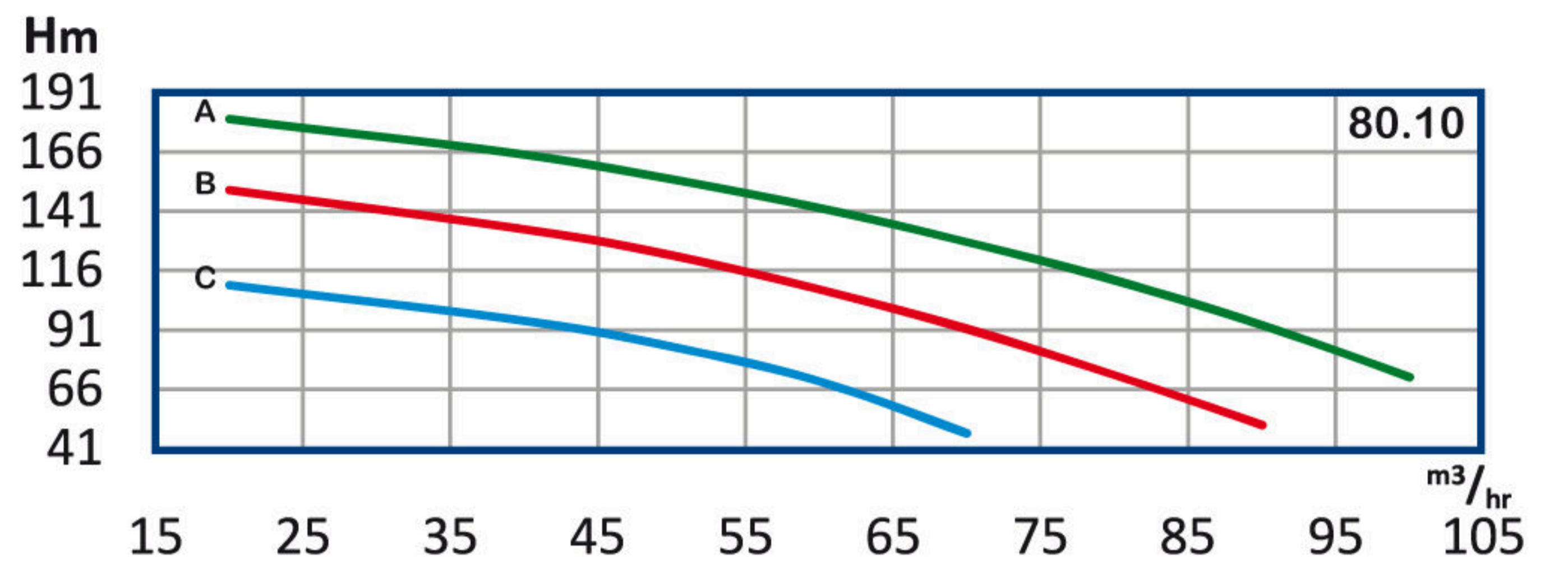
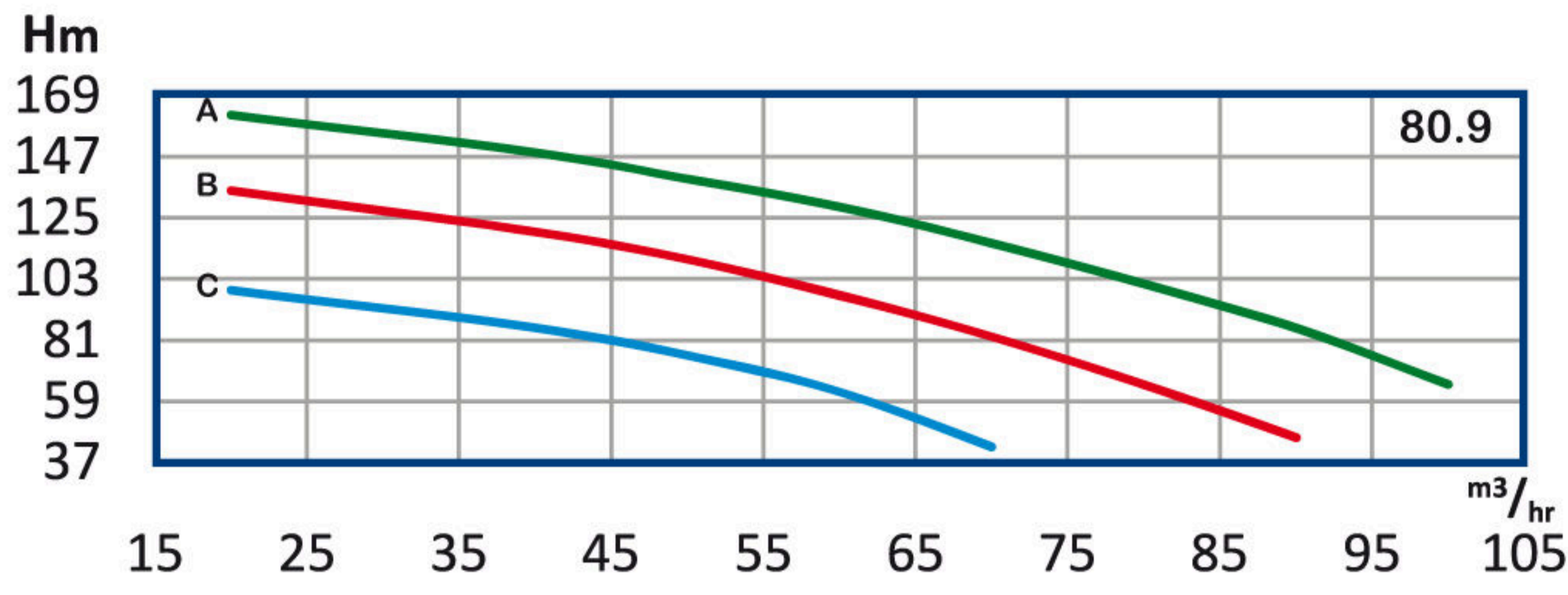

جدول طول پمپ WKL4 80 (mm)

تعداد طبقه	B	E	تعداد طبقه	B	E
1	110	230	7	608	728
2	193	313	8	691	811
3	276	396	9	774	894
4	359	479	10	857	977
5	442	562	11	940	1060
6	525	645	12	1023	1143

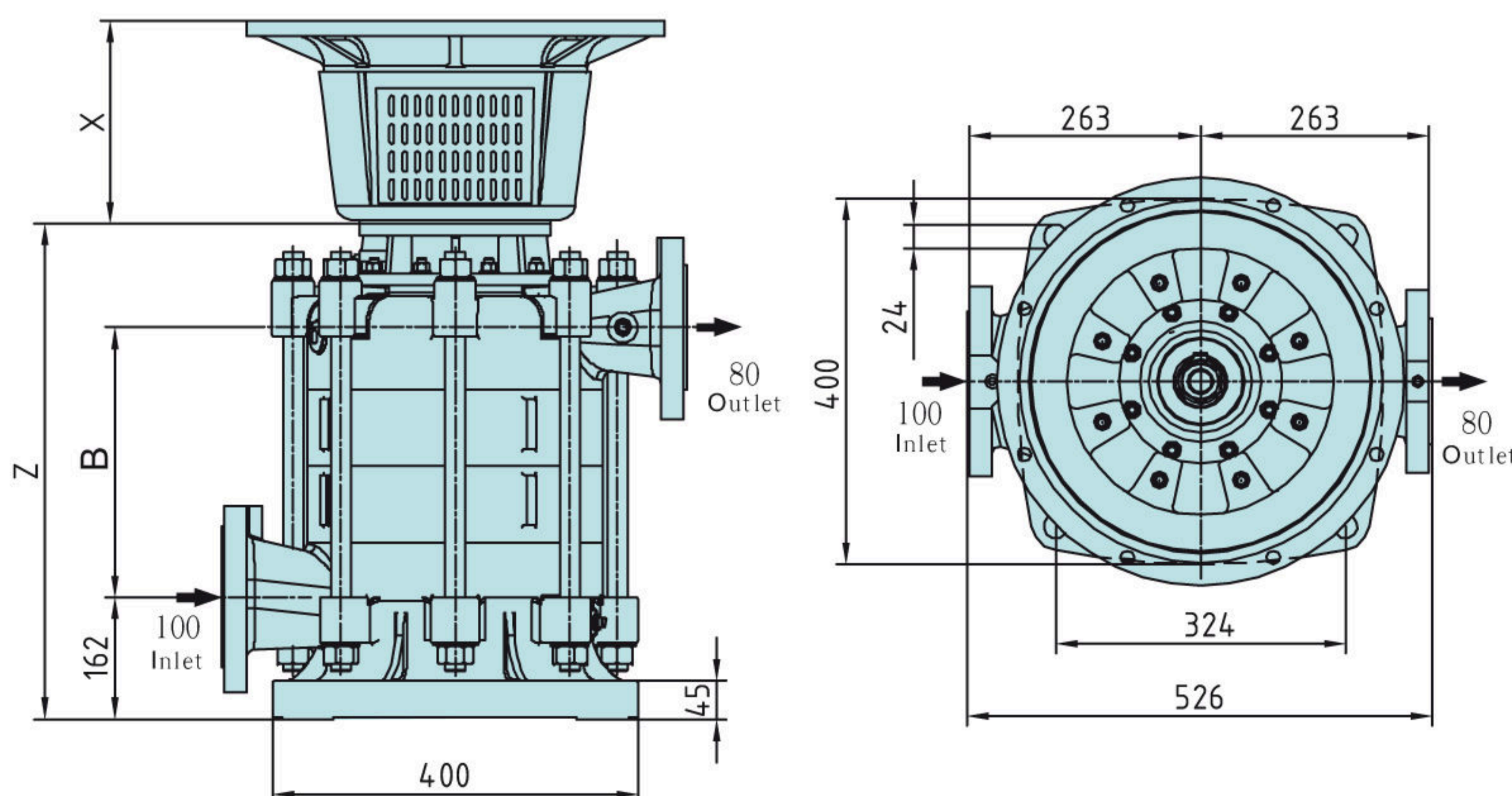

جدول طول پمپ WKL4 80 (mm)

تعداد طبقه	B	Z	تعداد طبقه	B	Z
1	95	435	7	593	933
2	178	518	8	676	1016
3	261	601	9	759	1099
4	344	684	10	842	1182
5	427	767	11	925	1265
6	510	850	12	1008	1348

X: متناسب با قدرت الکترو موتور تغییر می یابد.

n≈ 2900 rpm

پمپ 80 WKL, WKL

تیپ پمپ	توان P		آمپر A	قطر پروانه D (mm)	قطر فلنج mm		Q آبدھی								
	KW	HP			مکش	رانس	m3/h	H (m)							
								50	80	95	110	125	140	155	170
WKL 80.1 E	18.5	25	36	205-180	100	80	H (m)	13.9	22.3	26.4	30.6	34.7	38.9	43	47.3
WKL 80.1 D	22	30	42.5	205				44	39	35.5	30.5	24	*	*	*
WKL 80.1 C	30	40	57	210				57	53	50	46.5	42	37	30.5	*
WKL 80.1 B	30	40	57	215				62	58.2	55.2	51.8	47.4	42.7	36.8	30.5
WKL 80.1 A	37	50	69	220				66	62	59	55.5	51.3	46.8	41	35
WKL 80.2 E	30	40	57	205-180				69.5	65.3	62.3	59	55	50.5	45.5	40
WKL 80.2 D	45	60	83	205				88	78.5	71	61	48	*	*	*
WKL 80.2 C	55	75	104	210				113	106	101	93	84	74	61	0
WKL 80.2 B	55	75	104	215				123	116	111	104	94.8	85.2	73.6	61
WKL 80.2 A	75	100	140	220				131	124	118	111	103	93.4	82	70
WKL 80.3 E	45	60	83	205-180				137	130	125	118	110	101	91	80
WKL 80.3 D	75	100	140	205				130	118	107	91.5	72	*	*	*
WKL 80.3 C	75	100	140	210				169	159	151	140	126	111	91.5	*
WKL 80.3 B	90	125	166	215				184	175	166	155	142	128	110	91.5
WKL 80.3 A	110	150	200	220				196	186	177	167	154	140	123	105
WKL 80.4 E	60	80	124	205-180				205	195	187	177	165	152	137	120
WKL 80.4 D	90	125	166	205				175	157	142	122	96	*	*	*
WKL 80.4 c	110	150	200	210				225	212	201	186	168	148	122	*
WKL 80.4 B	110	150	200	215				245	233	222	207	190	170	147	122
WKL 80.4 A	132	180	240	220				261	248	237	222	205	187	164	140
					273	260	249	236	220	202	182	160			

H	m	23	46	69	91	114	137	160	183	206	229	251	274
	ft	75	150	225	300	375	450	525	600	675	750	825	900

Q	m3 /h	50	80	95	110	125	140	155	170
	g.p.m	190	303	360	416	473	530	587	644

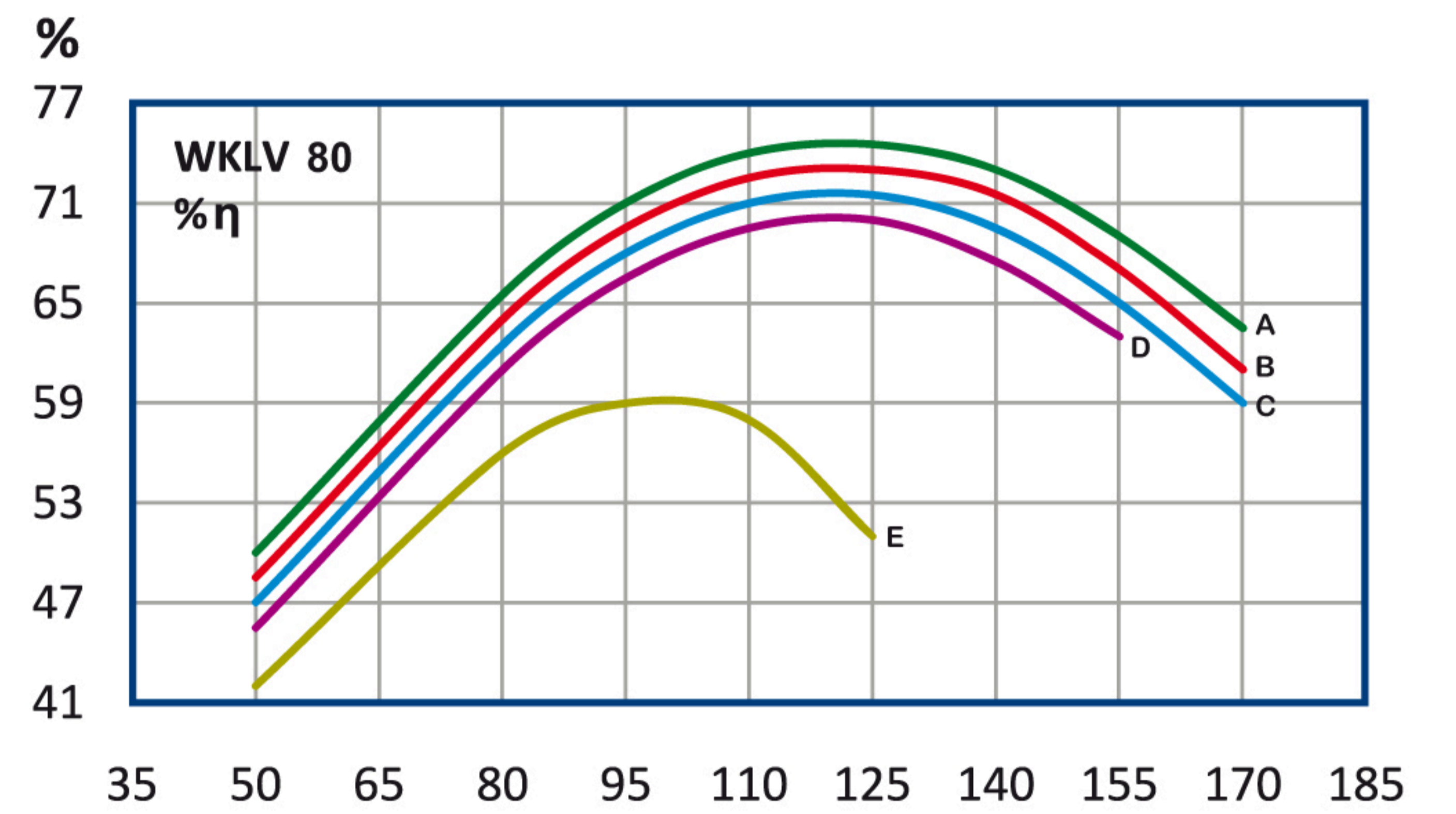
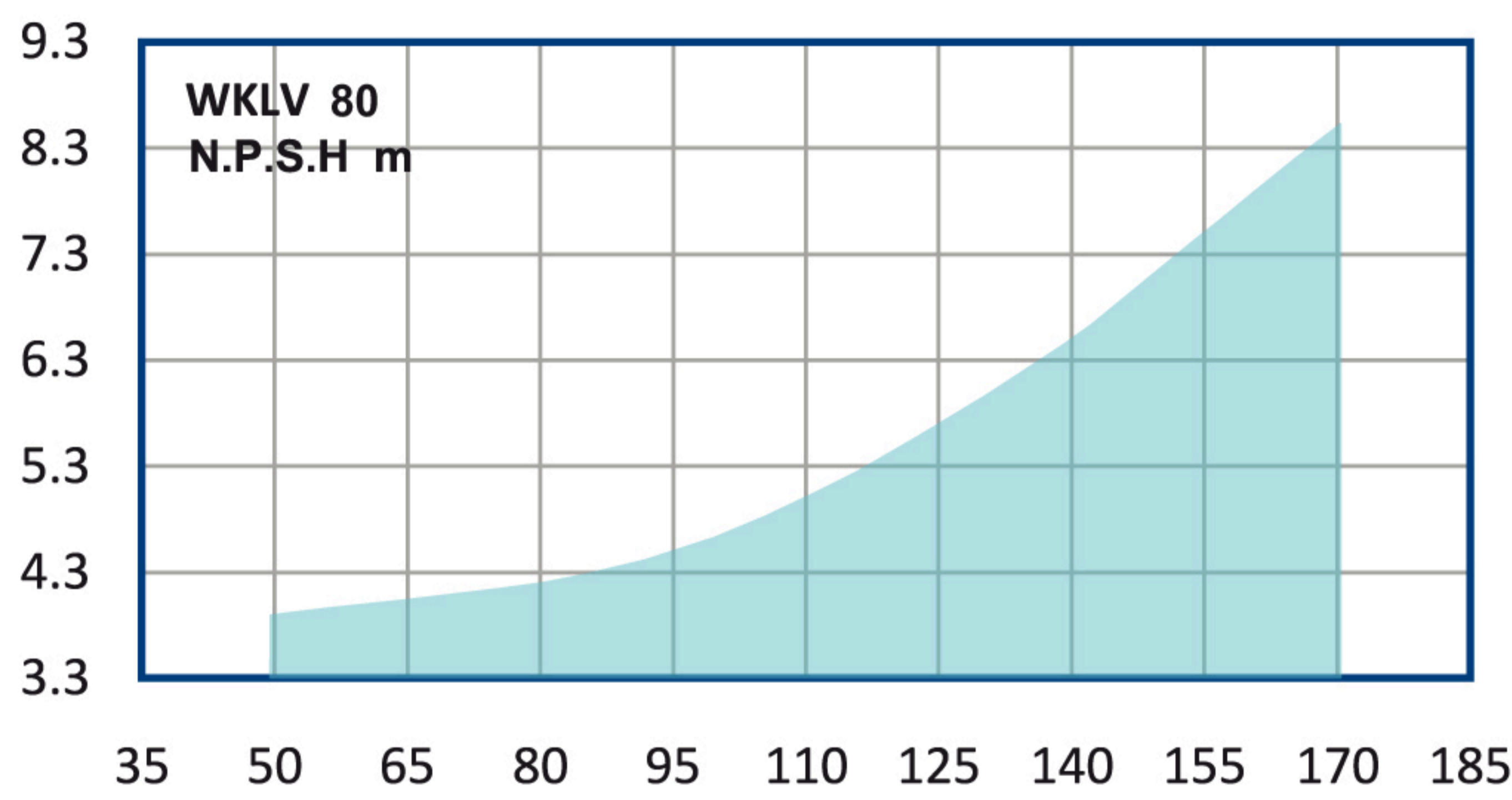
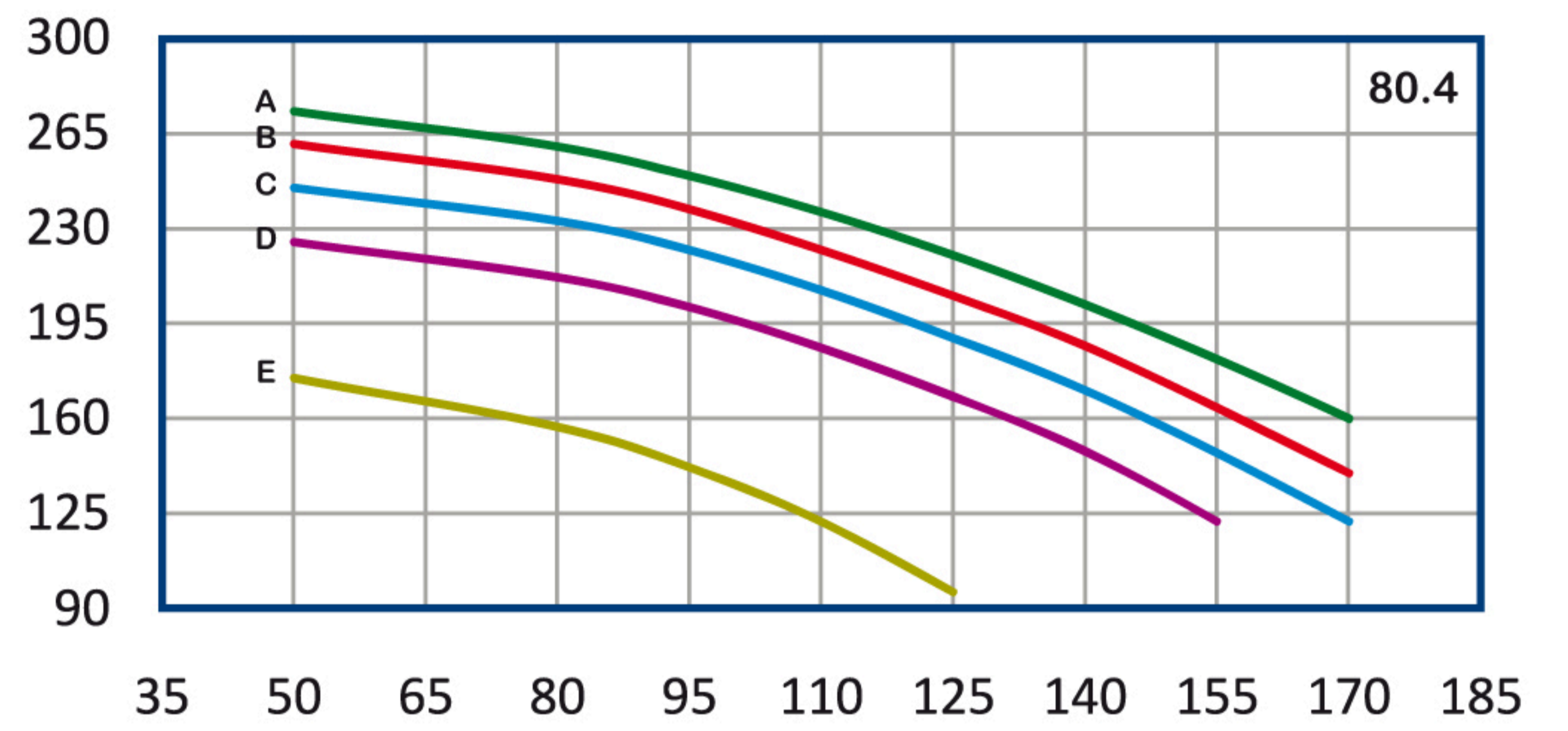
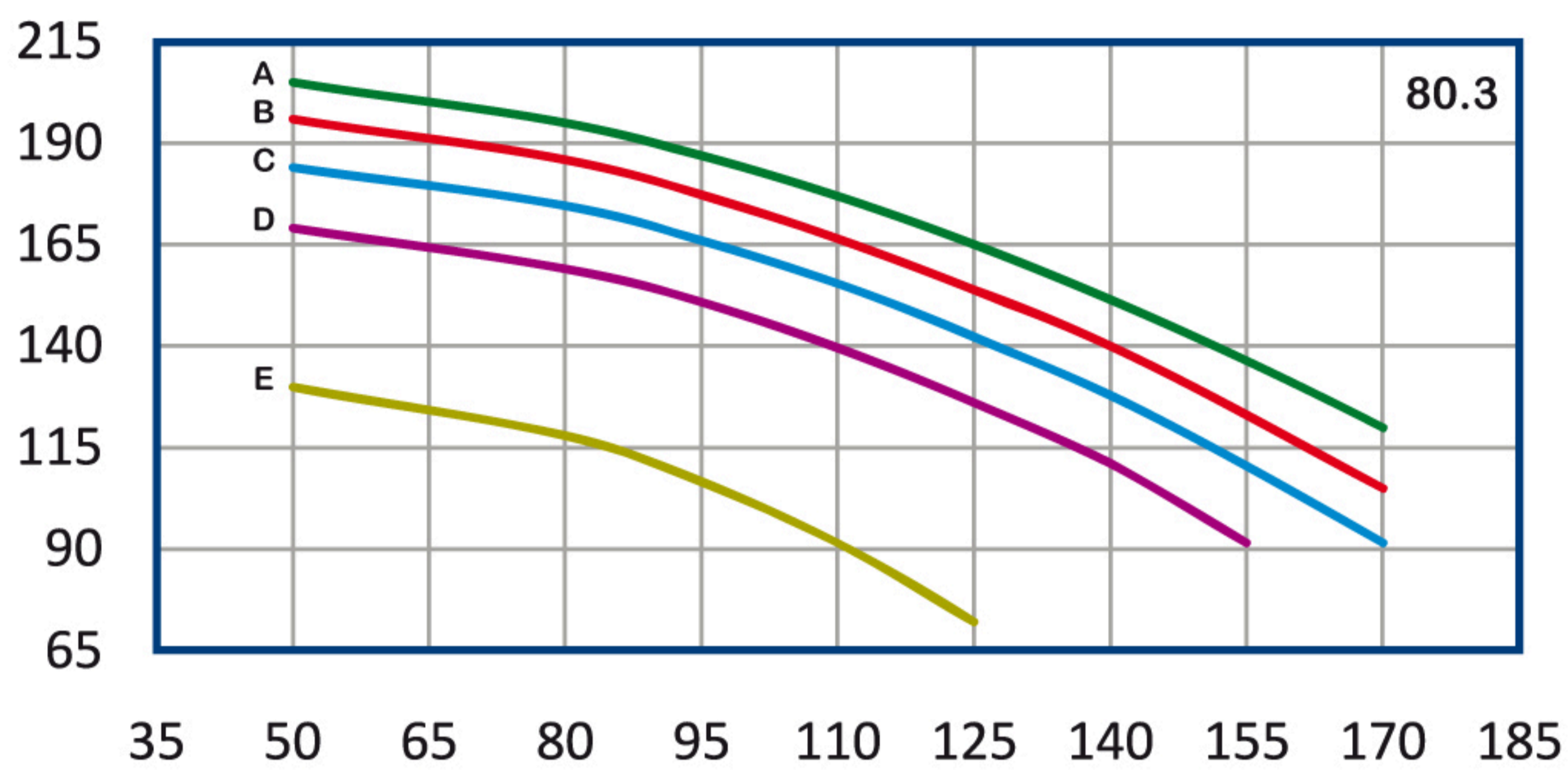
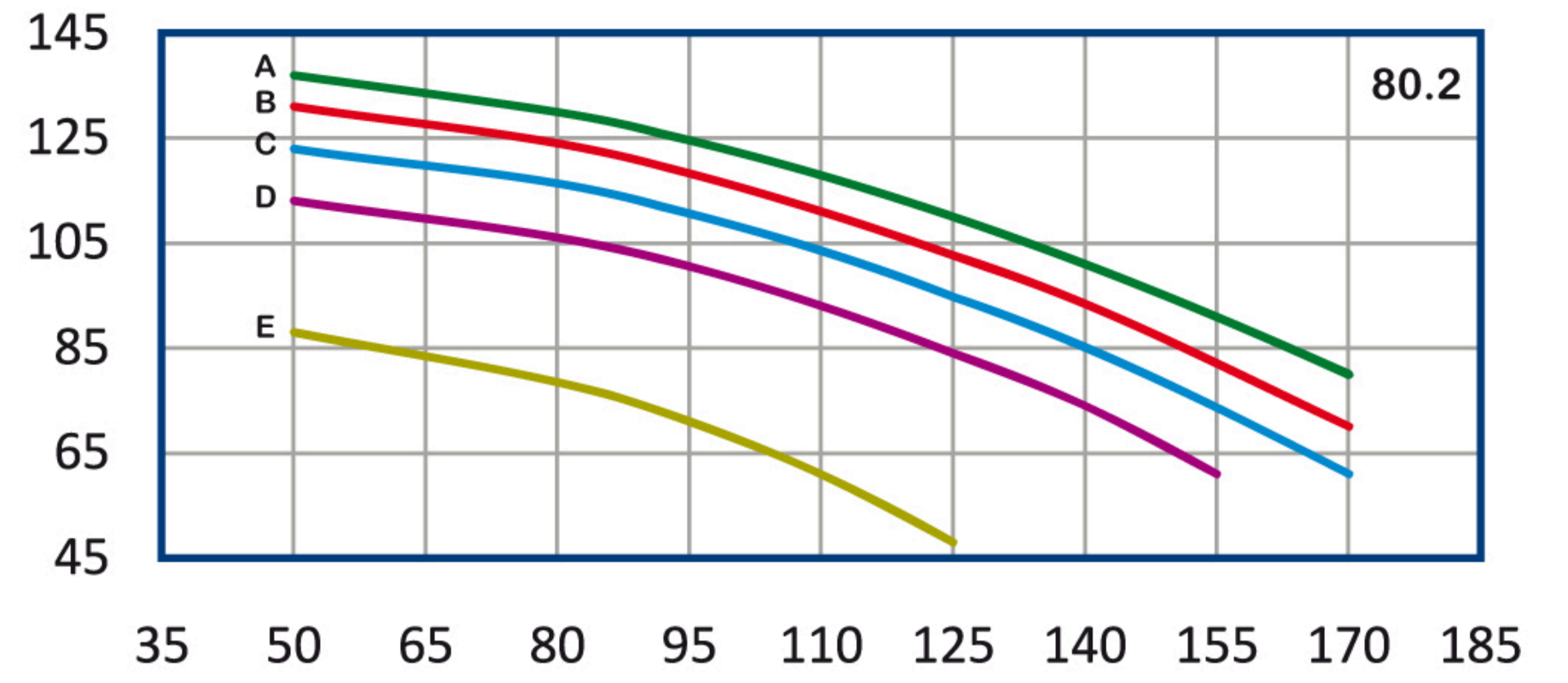
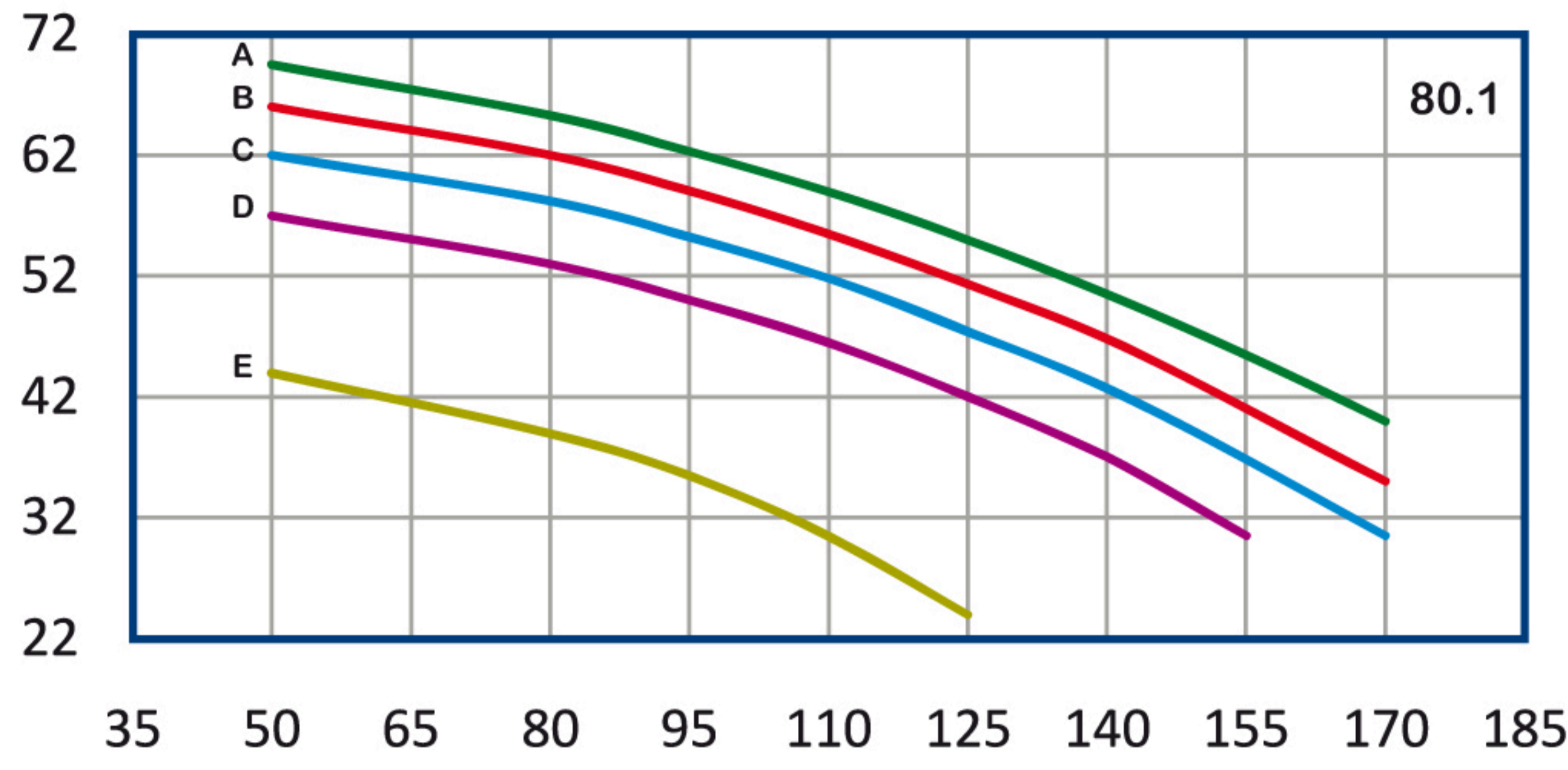

n≈ 2900 rpm

پمپ 80 WKL, WKL

تیپ پمپ	توان P		آمپر A	قطر پروانه D (mm)	قطر فلنج mm		Q آبدھی									
	KW	HP			مکش	رانس	H (m)	m ³ /h	50	80	95	110	125	140	155	170
								l/s	13.9	22.3	26.4	30.6	34.7	38.9	43	47.3
WKL 80.5 E	75	100	140	205-180	100	80	H (m)	219	197	178	153	120	*	*	*	
WKL 80.5 D	110	150	200	205				283	265	251	233	210	185	153	*	
WKL 80.5 C	132	180	240	210				308	291	277	259	237	213	184	153	
WKL 80.5 B	160	220	290	215				328	310	296	278	257	234	205	175	
WKL 80.5 A	160	220	290	220				343	325	312	295	275	253	228	200	
WKL 80.6 E	90	125	166	205-180				264	234	213	183	144	*	*	*	
WKL 80.6 D	132	150	200	205				342	318	301	279	252	222	183	*	
WKL 80.6 C	160	220	290	210				372	349	332	311	285	256	221	183	
WKL 80.6 B	160	220	290	215				396	372	354	333	308	281	246	210	
WKL 80.6 A	200	270	360	220				417	392	375	354	330	303	273	240	

H	m	119	137	155	180	204	229	259	290	320	354	387	420
	ft	390	450	510	590	670	750	850	950	1050	1160	1270	1380

Q	m ³ /h	50	80	95	110	125	140	155	170
	g.p.m	190	303	360	416	473	530	587	644

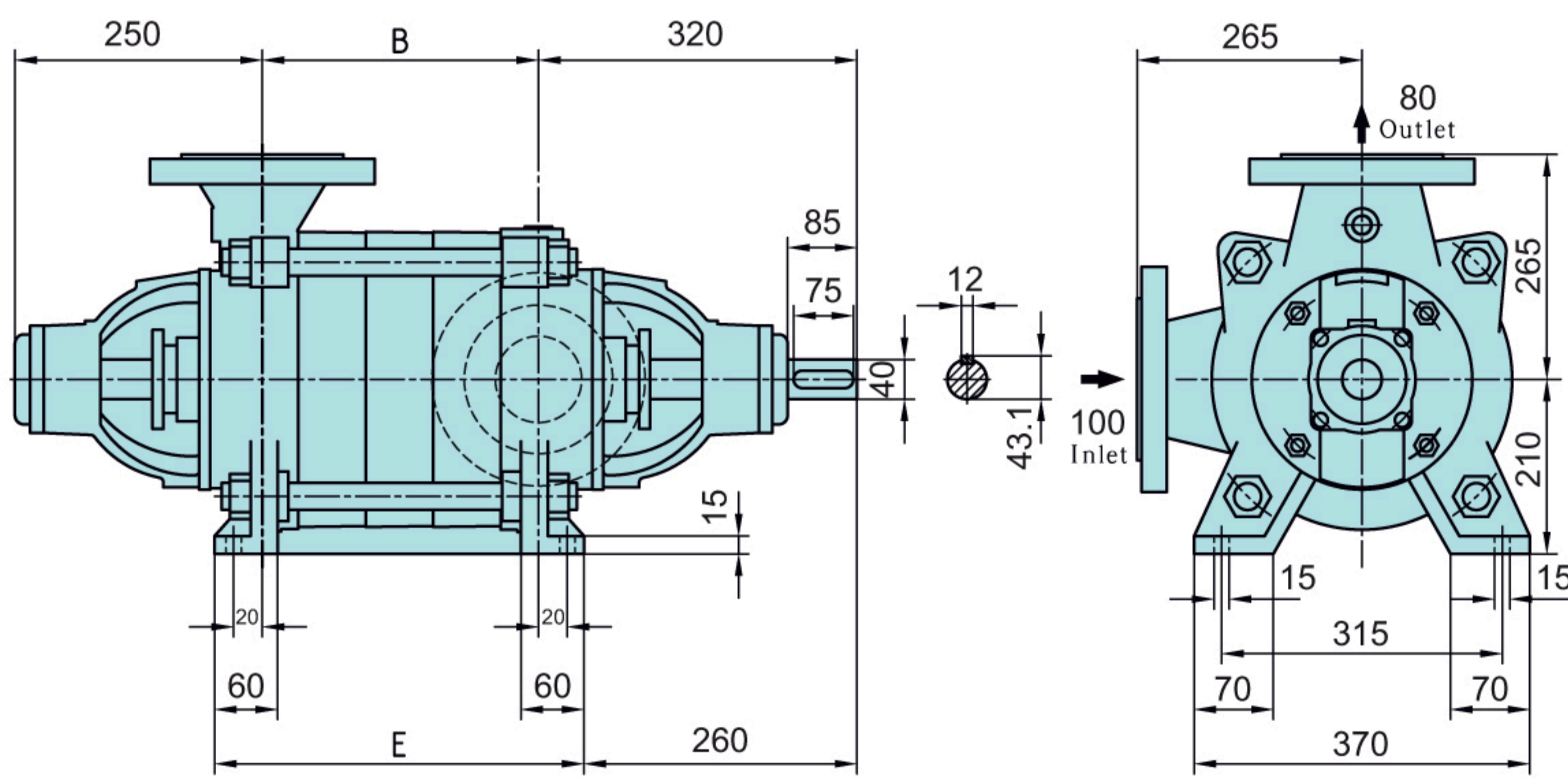
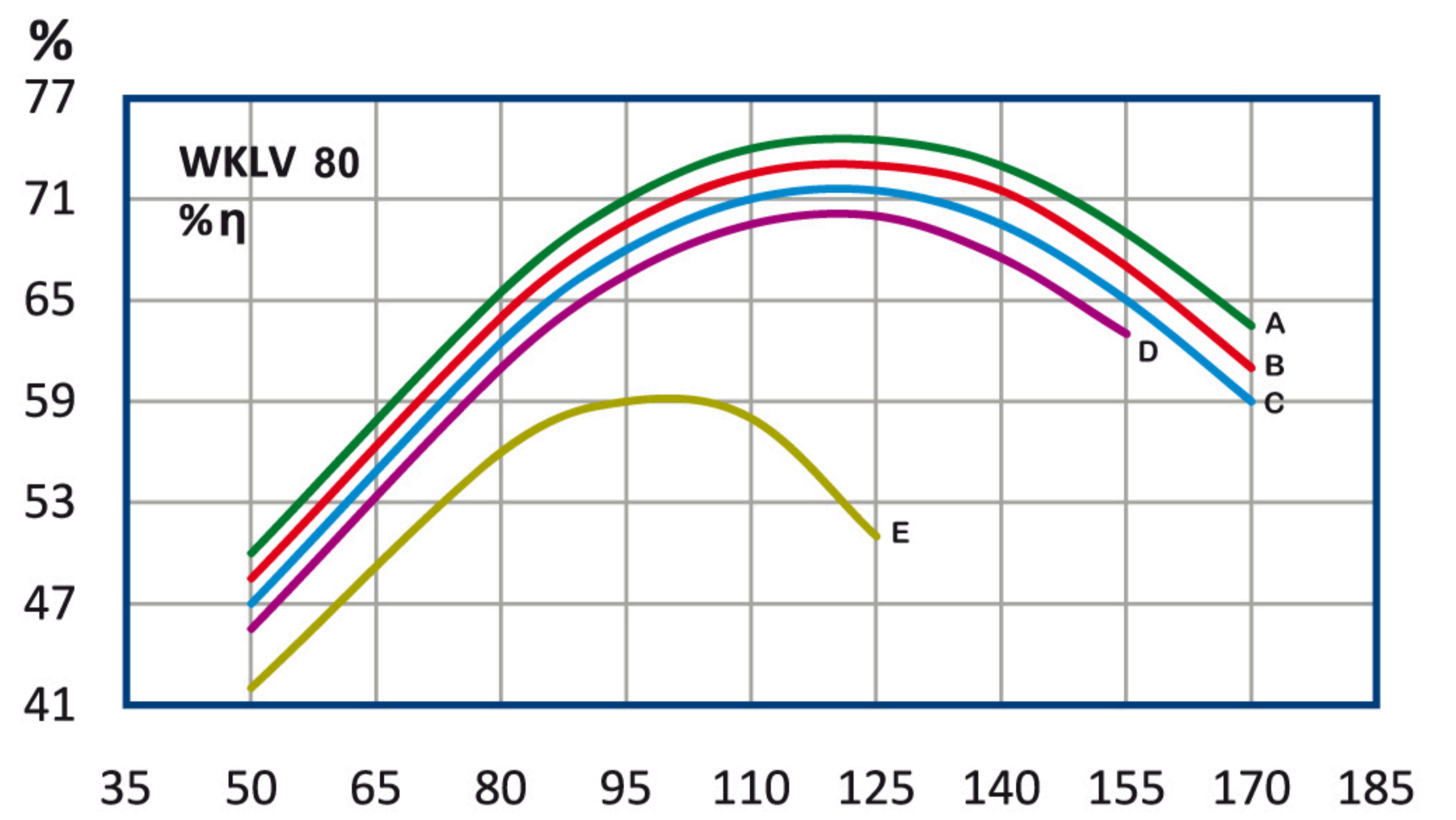
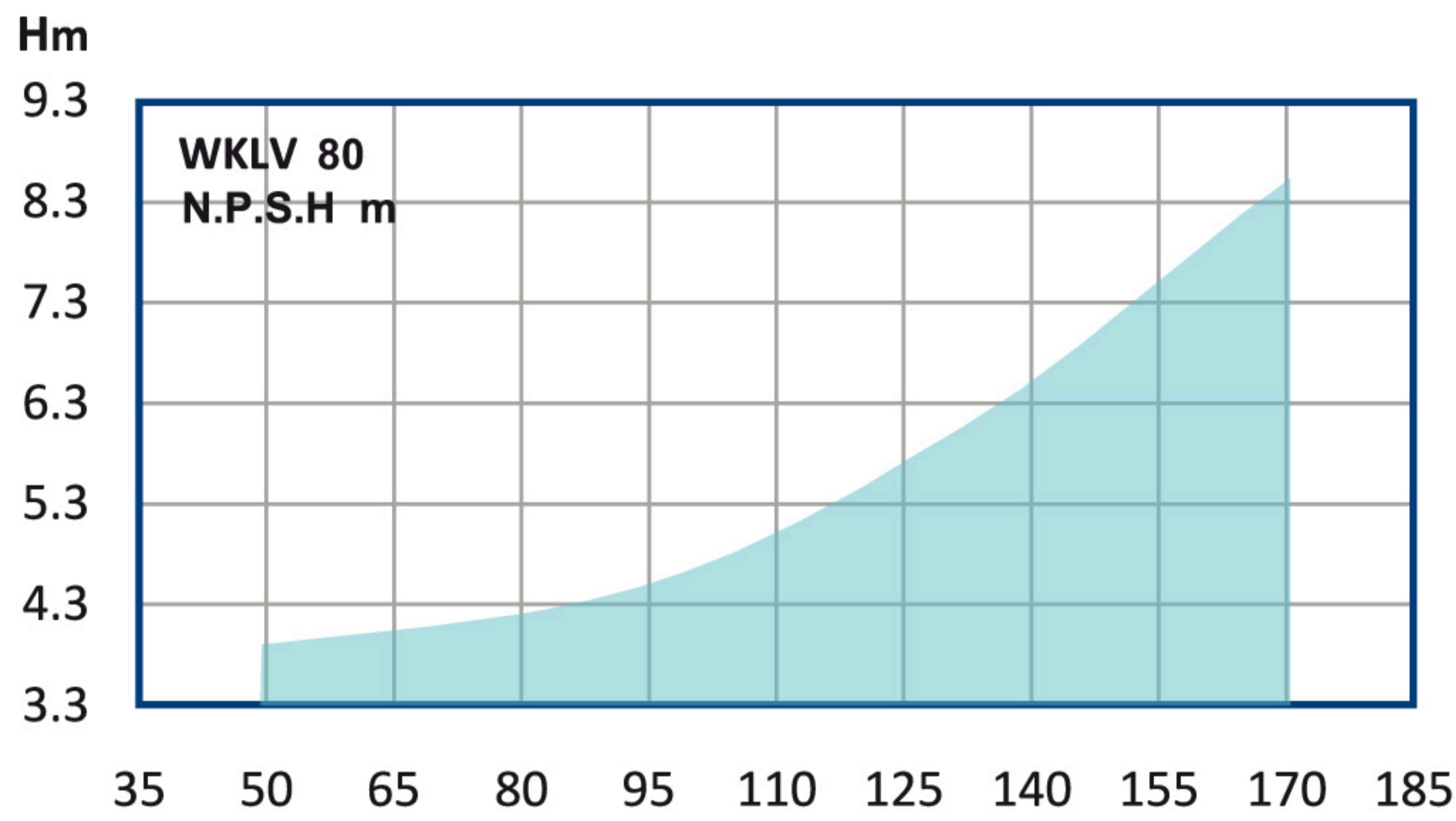
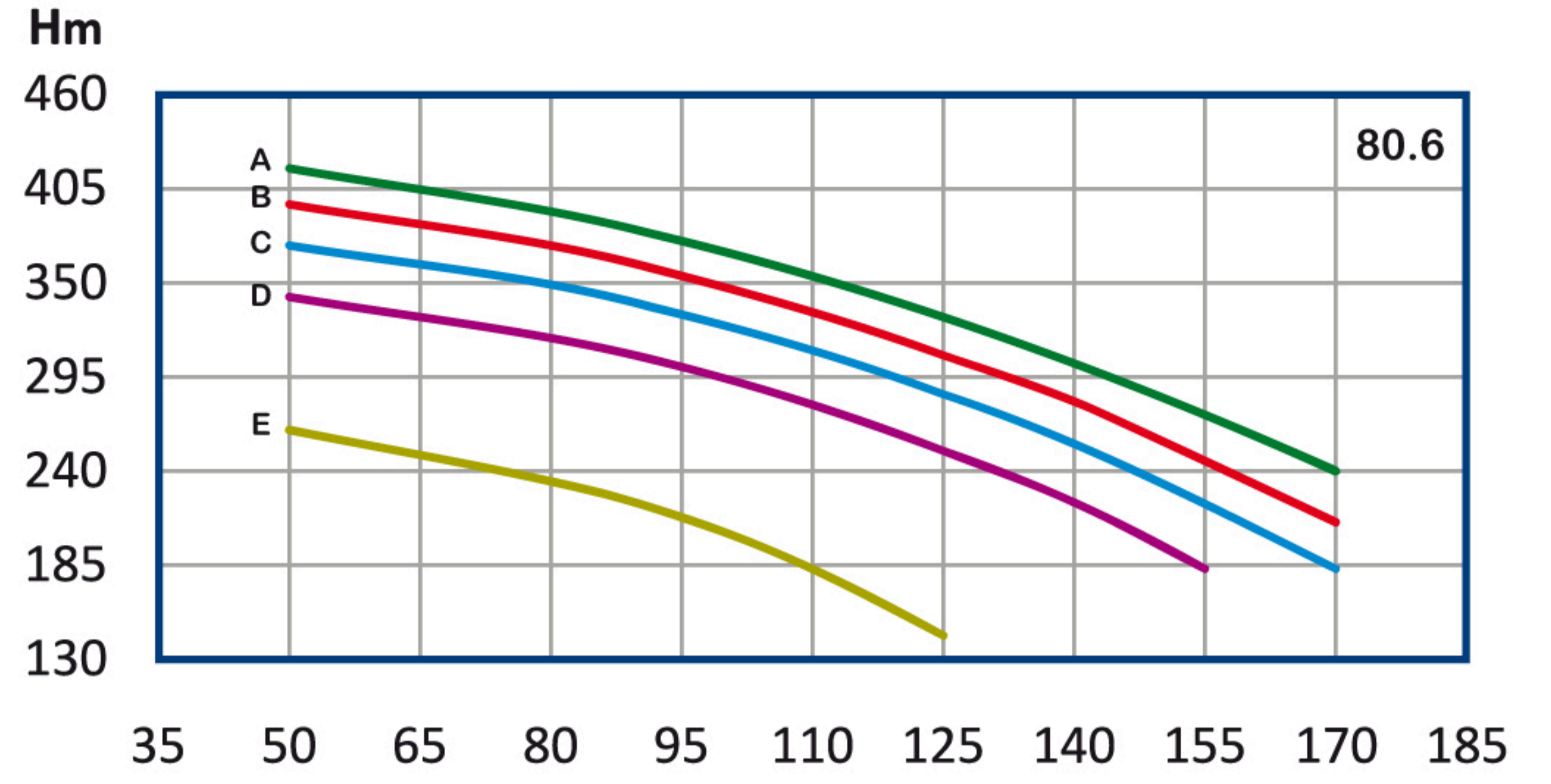
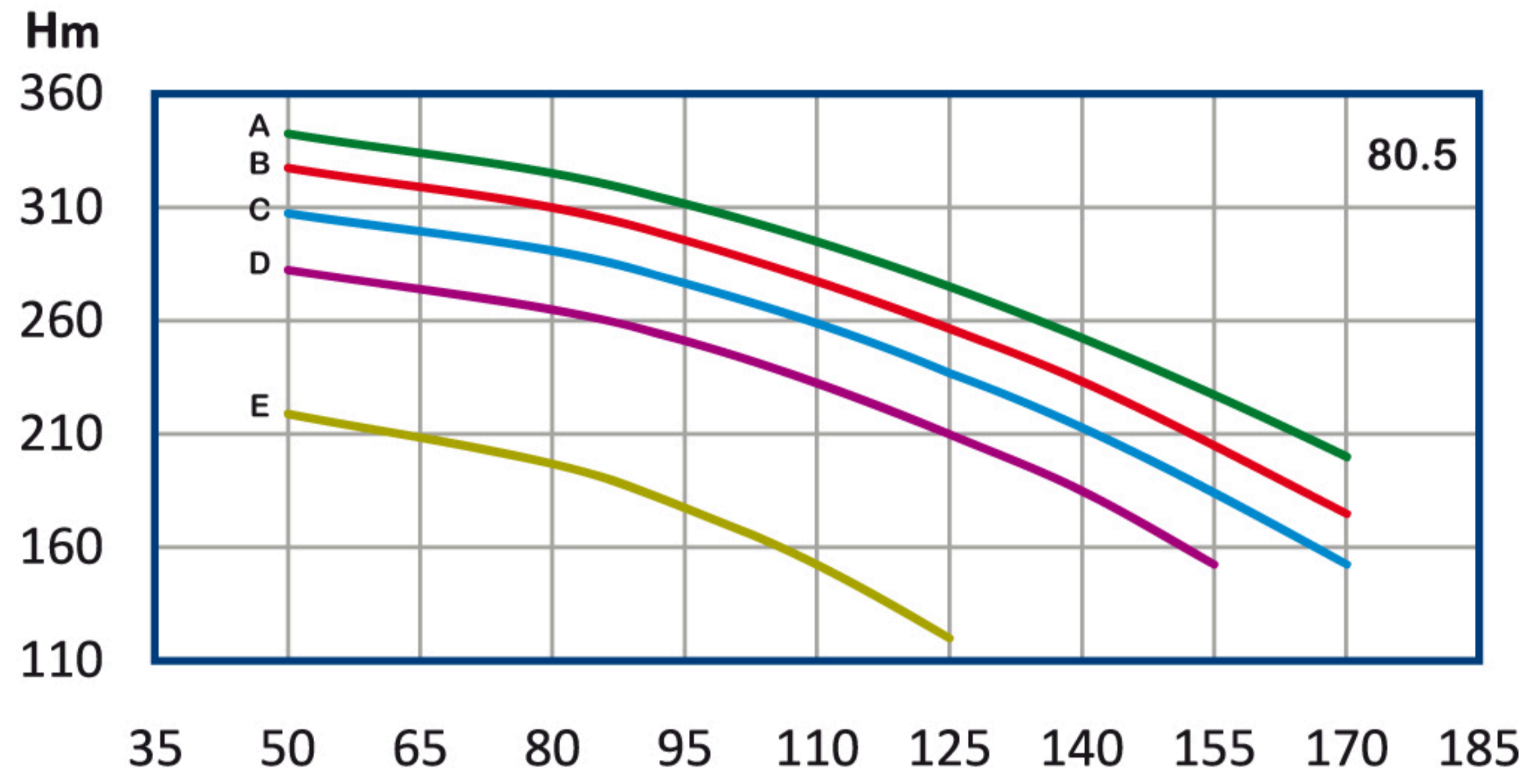

جدول طول پمپ (mm) WKL 80

تعداد طبقه	B	E	تعداد طبقه	B	E
1	110	330	4	359	479
2	193	313	5	442	562
3	276	396	6	525	645

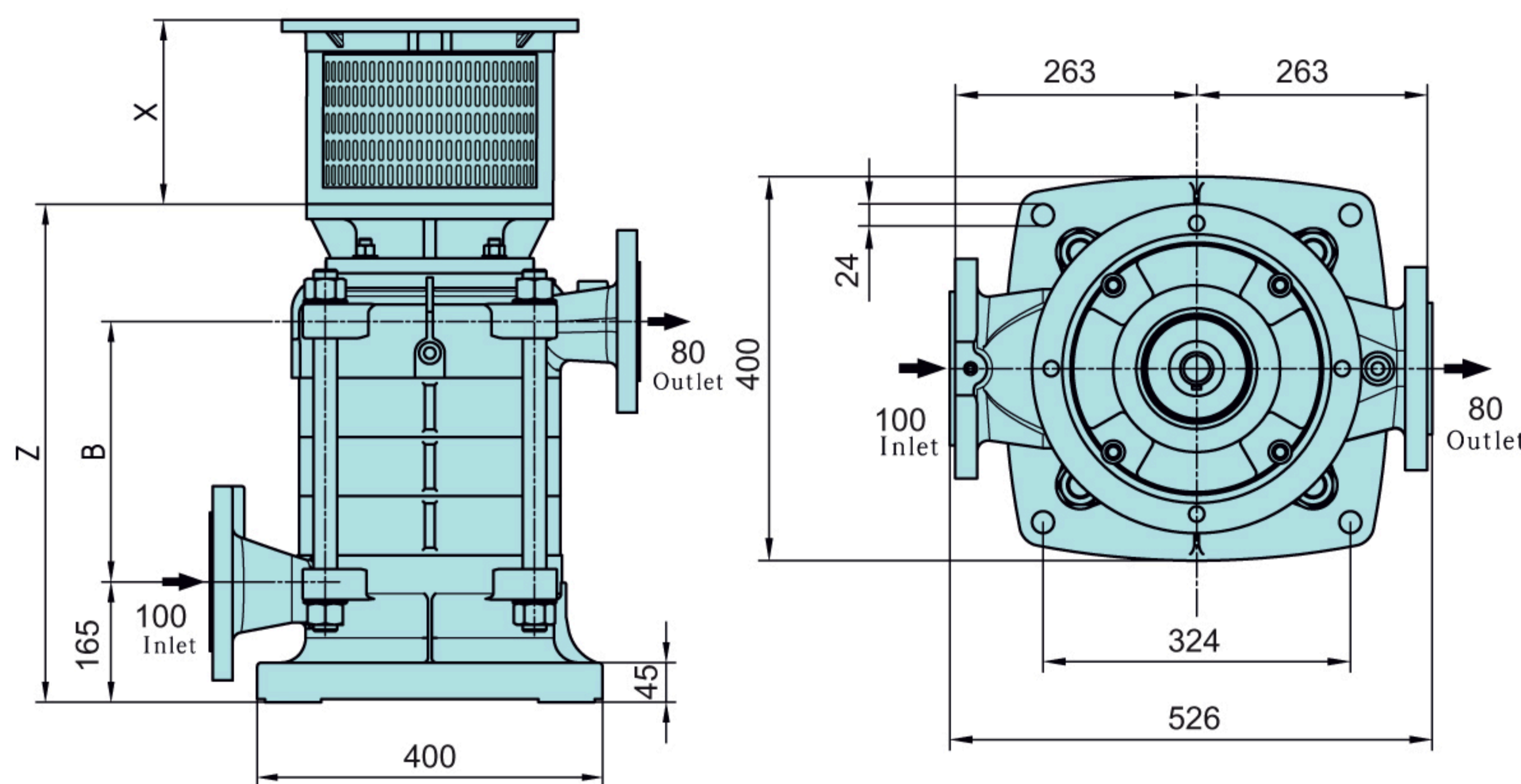

جدول طول پمپ (mm) WKL 80

تعداد طبقه	B	Z	تعداد طبقه	B	Z
1	95	435	4	344	684
2	178	518	5	427	767
3	261	601	6	510	850

X: متناسب با قدرت الکترو موتور تغییر می یابد.

جدول ابعاد پمپ های WKLV4 , WKLV (80-150)

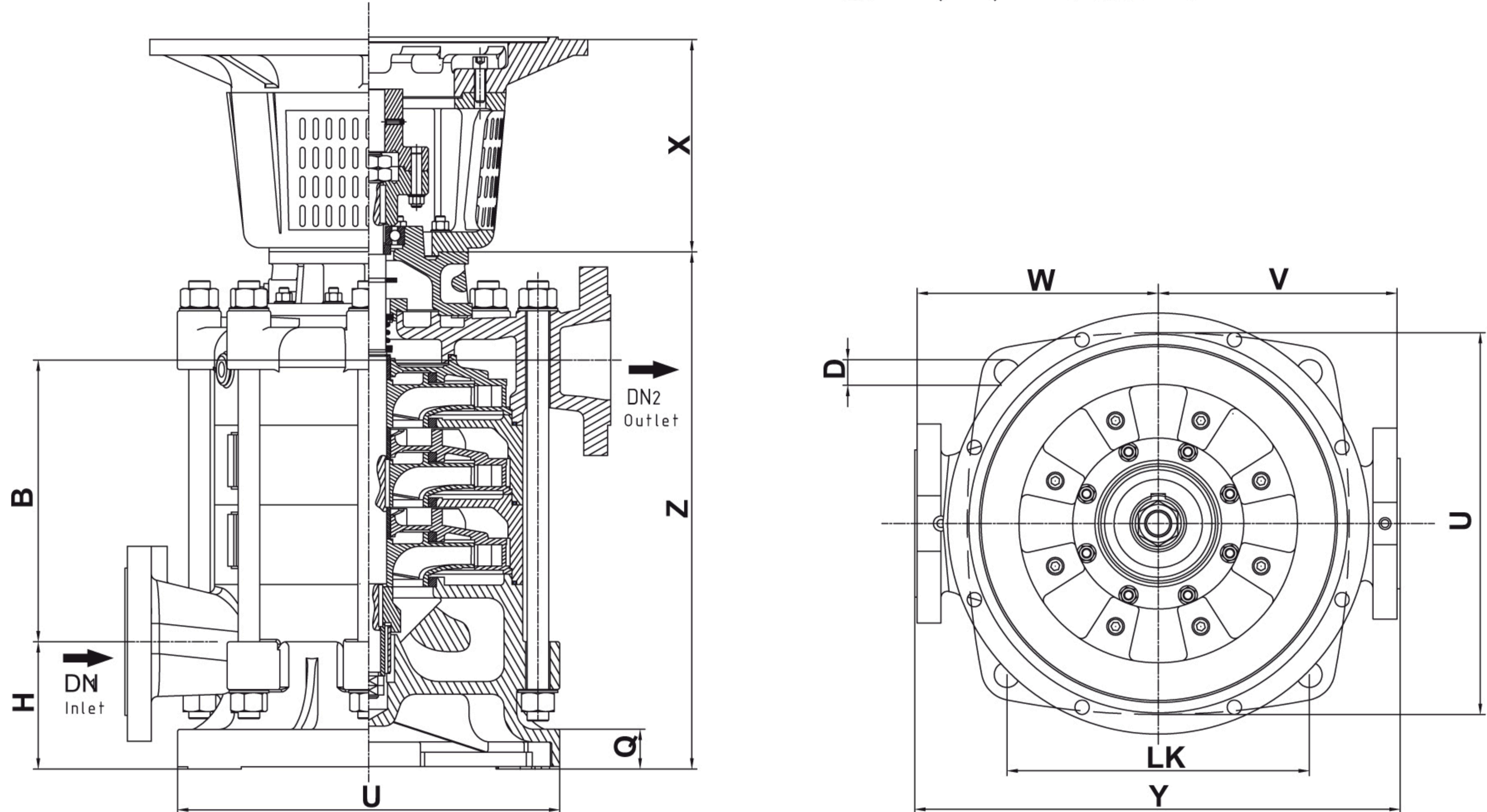

Type	(mm)									
	DN1	DN2	LK	Y	U	D	W	V	Q	H
WKLV4 / WKLV 80	100	80	324	526	400	24	260	260	45	162
WKLV4 100	125	100	380	610	480	32	303	300	50	160
WKLV4 125	150	125	523	769	660	40	385	384	85	249
WKLV4 150	200	150	545	865	685	40	430	435	85	276

Type	طول پمپ	(mm)											
		1	2	3	4	5	6	7	8	9	10	11	12
WKLV4 / WKLV 80	B	95	178	261	344	427	510	593	676	759	842	925	1009
	Z	401	484	567	650	733	816	899	982	1065	1148	1231	1314
WKLV4 100	B	154	254	354	454	554	654	754	854	954	1054	*	*
	Z	450	550	650	750	850	950	1050	1150	1250	1350	*	*
WKLV4 125	B	172	287	402	517	632	747	*	*	*	*	*	*
	Z	631	746	861	976	1091	1206	*	*	*	*	*	*
WKLV4 150 Type A	B	214	359	504	649	794	939	*	*	*	*	*	*
	Z	750	895	1040	1185	1330	1475	*	*	*	*	*	*
WKLV4 150 Type B	B	214	359	504	649	794	939	*	*	*	*	*	*
	Z	730	875	1020	1165	1310	1455	*	*	*	*	*	*